

LOW PROFILE PARTS HOPPER - HOP-LP-N

APPROX WEIGHT: 209.10 lbs.
DOES NOT INCLUDE WEIGHT OF POWER OR PACKAGING!!!

*** ANY ADDITIONS, DELETIONS, OR OMISSIONS MUST BE CORRECTED ON THIS DRAWING AS THIS DRAWING WILL BE CONSIDERED ALL INCLUSIVE ***

ALL GRAPHICS PROVIDED ARE FOR REFERENCE ONLY. IF CERTAIN DIMENSIONS ARE CRITICAL PLEASE VERIFY THOSE DIMENSIONS WITH YOUR SALESPERSON

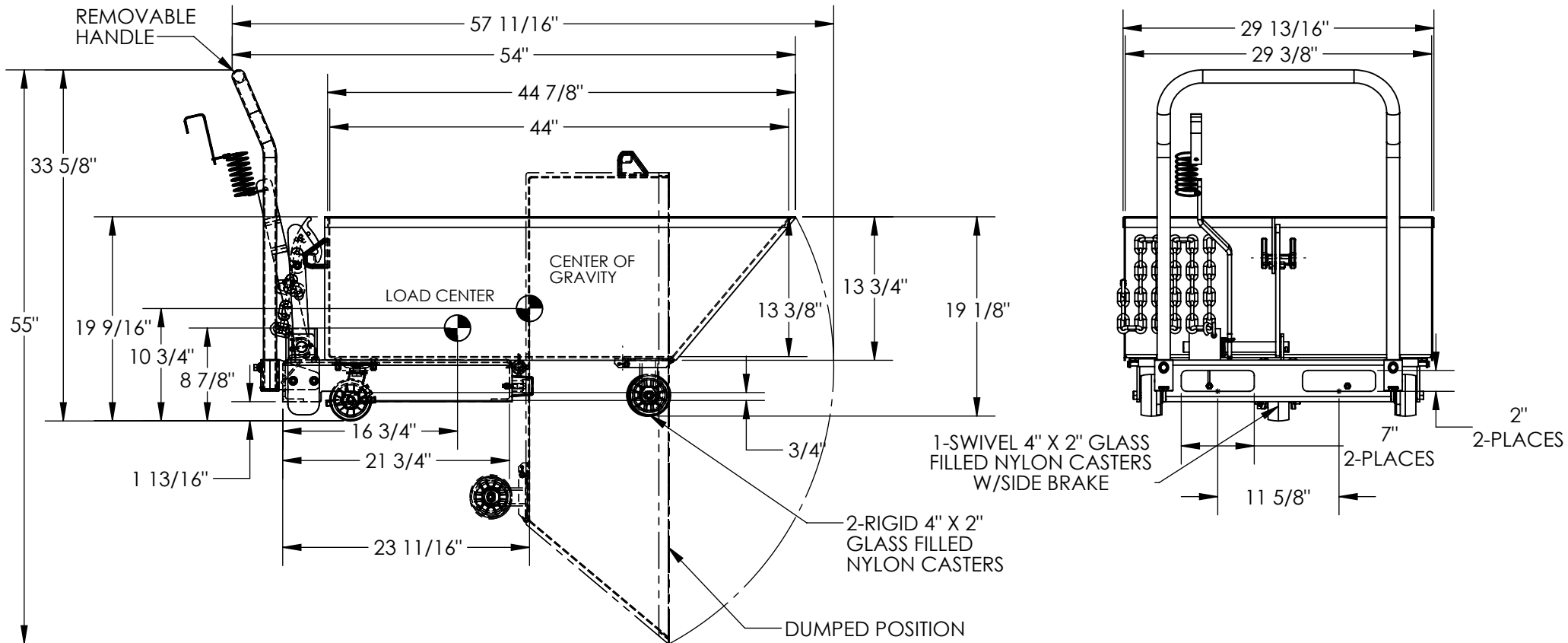

NEVER EXCEED LOAD CENTER RATING PER FORK TRUCK MANUFACTURER'S GUIDELINES. DO NOT USE THIS FORK TRUCK ATTACHMENT IF LOAD WILL EXCEED FORK TRUCK MANUFACTURER'S LOAD CENTER RATING.
APPROX. WEIGHT/ LOST LOAD=209.10 LBS.
EFFECTIVE THICKNESS= FORK LENGTH MINUS 21 3/4"

STANDARD FEATURES

- MODEL NUMBER IS HOP-LP-N
- CAPACITY: 2,000 LBS.
- VOLUME: 1/3 CUBIC YARD
- OVERALL WIDTH: 29 13/16"
- OVERALL LENGTH: 54"
- OVERALL HEIGHT: 33 5/8"
- WORK ENVELOPE: 29 13/16"X57 11/16"X55"
- CHUTE SIZE: 29 13/16"X44 7/8"X13 3/4"
- RELEASE CABLE LENGTH: AT LEAST 48"
- FORK POCKETS: 7" W X 2", 11 5/8" ON CENTER
- 1-SWIVEL 4" X2" GLASS FILLED NYLON CASTERS W/ LOCK
- 2- RIGID 4"X2" GLASS FILLED NYLON CASTERS
- TOUGH BAKED IN POWDER COATED BLUE FINISH

SPECIAL FEATURES

NONE

DIMENSION TOLERANCE ± 1/4"

A
P
P
R
O
V
A
L

I, THE UNDERSIGNED, AGREE THAT THE PRODUCT AS REPRESENTED SATISFIES DESIGN AND DIMENSION REQUIREMENTS. I ALSO ACKNOWLEDGE MY DUTY TO CONFIRM PRODUCT AND INSTALLATION COMPLIANCE WITH ALL APPLICABLE FEDERAL, STATE AND LOCAL REGULATIONS AND STANDARDS.
UNITS REQUIRING APPROVAL DRAWINGS OR MODIFIED ARE NON-RETURNABLE
[] As drawn [] As marked

Signed: _____ Date: _____

Printed Name: _____

LEAD TIME WILL START UPON RECEIPT OF SIGNED APPROVAL DRAWING

DISTRIBUTOR'S NAME:		P.O.#
		X
		W.O.#
		X
DRAWN BY:	CRM	DATE:
		02/11/2011
REFERENCE:	X	SCALE: 1:14
		FILE NAME:
QUOTED LEAD TIME:	X	QUOTE #
		X
		37-007-084