



## LAD-FM-PSO Mezzanine Ladders



### Receiving Instructions

After delivery, remove the packaging from the product. Inspect the product closely to determine whether it sustained damage during transport. If damage is discovered, record a complete description of it on the bill of lading. If the product is undamaged, discard the packaging.

**NOTE:** The end-user is solely responsible for confirming that product design, use, and maintenance comply with laws, regulations, codes, and mandatory standards applied where the product is used.

### Technical Service & Replacement Parts

For answers to questions not addressed in these instructions and to order replacement parts, labels, and accessories, call our Technical Service and Parts Department at (260) 665-7586. The Department can also be contacted online at <https://www.vestil.com/page-parts-request.php>.

### Electronic Copies of Instruction Manuals




Additional copies of this instruction manual may be downloaded from <https://www.vestil.com/page-manuals.php>.

### Table of Contents

	Page
Signal Words.....	2
Safety Instructions.....	2 - 3
Specifications.....	3
FIG. 1: LAD-FM-60-PSO Exploded View and Bill of Materials.....	4
FIG. 2: LAD-FM-72-PSO Exploded View and Bill of Materials.....	5
FIG. 3: LAD-FM-84-PSO Exploded View and Bill of Materials.....	6
FIG. 4: LAD-FM-96-PSO Exploded View and Bill of Materials.....	7
FIG. 5: LAD-FM-108-PSO Exploded View and Bill of Materials.....	8
FIG. 6: LAD-FM-120-PSO Exploded View and Bill of Materials.....	9
FIG. 7: Cable hoist, mounting bracket, cable grabber, and handheld controller.....	10
Assembly & Installation.....	10 - 17
Using the Mezzanine Ladder.....	17
Electrical Circuit Diagram.....	18
Record of Satisfactory Condition.....	19
Inspections & Maintenance.....	19 - 20
Labeling Diagram.....	20
Limited Warranty.....	21

## SIGNAL WORDS

SIGNAL WORDS appear in this manual to draw the reader's attention to important safety-related messages. The following are signal words used in this manual and their definitions.

 <b>DANGER</b>	Identifies a hazardous situation which, if not avoided, <b>WILL</b> result in <b>DEATH</b> or <b>SERIOUS INJURY</b> . Use of this signal word is limited to the <b>most extreme situations</b> .
 <b>WARNING</b>	Identifies a hazardous situation which, if not avoided, <b>COULD</b> result in <b>DEATH</b> or <b>SERIOUS INJURY</b> .
 <b>CAUTION</b>	Indicates a hazardous situation which, if not avoided, <b>COULD</b> result in <b>MINOR</b> or <b>MODERATE</b> injury.
<b>NOTICE</b>	Identifies practices likely to result in <b>product/property damage</b> , such as operation that might damage the product.

## SAFETY INSTRUCTIONS

Vestil strives to identify foreseeable hazards associated with the use of its products. However, no manual can address every conceivable risk that could arise from using a ladder. Always apply good judgment while using this mezzanine ladder system.

### **WARNING**

If this product is installed, used, or maintained improperly serious personal injuries or death might result.

- **Read and understand the entire manual before installing, using, or servicing the product.** Keep this manual in a location known to persons who use the dock leveler. Read the manual whenever necessary to refresh your understanding of proper use, inspection, and maintenance procedures.
- DO NOT exceed the capacity: 350 pounds (159kg). The total weight applied to the ladder (weight of the user plus tools, etc.) must not be greater than the capacity. Capacity is provided on your [SPECIFICATIONS](#) document as well as on label 1153. See [LABELING DIAGRAM](#) on p. 20.
- DO NOT use the stairway if any unusual noise or movement is observed while weight is applied to it. If a malfunction occurs, remove the unit from service and notify your supervisor or maintenance personnel about the issue. DO NOT return the ladder to service until qualified maintenance personnel determine that it is in [SATISFACTORY CONDITION](#). See [RECORD OF SATISFACTORY CONDITION](#) on p 19.
- DO NOT use the stairway UNLESS it is securely fastened to the mezzanine.
- DO NOT store articles on the stairs.
- **DO NOT use this ladder unless you are in good health. NEVER use the ladder while under the influence of alcohol or drugs, including prescription medication that affects balance, perception, or judgment.**
- Wear appropriate footwear. DO NOT wear high-heeled shoes or footwear with smooth soles.
- DO NOT contact overhead objects with either your body or with the ladder during use.
- Avoid electrical shock! Avoid contact, or possible contact, with energized electrical lines while installing, assembling, using, maintaining, or storing the ladder.
- Remove foreign matter, e.g. mud, from your shoes before walking on the ladder. Only wear slip-resistant shoes.
- Only stand on the steps. DO NOT climb onto the railing. DO NOT slide on the railing.
- DO NOT access, or egress from, any step from an elevated location other than the mezzanine to which the ladder is attached.
- ALWAYS face the stairs and use the handrails while ascending and descending the ladder.
- DO NOT increase the height of any step by standing on other objects placed on the ladder.
- Inspect the ladder as described in [INSPECTIONS & MAINTENANCE](#) on p. 19-20. DO NOT use the ladder unless it is in [SATISFACTORY CONDITION](#). ONLY use manufacturer-approved replacement parts to repair the ladder.
- ONLY use the ladder to access the mezzanine to which the ladder is attached. DO NOT use the ladder for any other purpose. DO NOT store materials and/or equipment on the steps.
- DO NOT lean, or reach, over the handrails or guardrails of the ladder. Overreaching could cause instability and result in a fall. Avoid sudden shifts while on the ladder. DO NOT push, pull, or lean on the handrails or guardrails.
- DO NOT skip steps. Climb the ladder one step at a time.
- DO NOT attempt to extend or retract the ladder while someone is using it. The ladder must be unoccupied before it is moved.

## ⚠ WARNING

- DO NOT ride on the ladder. Only climb the ladder when it is in the fully extended/lowered position. DO NOT climb the ladder when it is retracted *EVEN IF* the floor lock is applied.
- DO NOT remove or obscure any label. Each label must be readable, undamaged, and present in the appropriate location. See [LABELING DIAGRAM](#) on p. 20.
- DO NOT modify this ladder! Modifications automatically void the [LIMITED WARRANTY](#) on p. 21 and might make the ladder unsafe to use.
- Only locking fasteners should be used. During assembly, confirm that there are only locking nuts. Contact [TECHNICAL SERVICE](#) (p. 1) if you find non-locking nuts. Lock nuts can only safely be used once. Discard used lock nuts and install new lock nuts after unfastening any connection.

## NOTICE

- Proper installation, use, and maintenance are essential for this product to function properly.
- Always use this product in accordance with the instructions in this manual.
  - Keep the stairs clean & dry. Periodically lubricate pivot points.

## SPECIFICATIONS

Documents that provide specifications for LAD-FM-##-PSO series ladders are available online to anyone who visits Vestil's website. Specifications include dimensions, net weight, and capacity information. To access the appropriate specifications document, navigate to this webpage: <https://www.vestil.com/product.php?FID=611>. Click the *Product Specifications Table* tab. Scroll the page to the entry for the model you purchased, and click the button in the *PDF* column that looks like a pencil inside a box. A PDF file will open. This file is the specifications document for your dock leveler. Print a copy of the document and keep it with your copy of this manual. The following is an exemplar specifications document for model LAD-FM-60-PSO.

### FOLDING MEZZANINE LADDER 115VAC PWR, LAD-FM-60-PSO

\*\*\* ANY ADDITIONS, DELETIONS, OR OMISSIONS MUST BE CORRECTED ON THIS DRAWING AS THIS DRAWING WILL BE CONSIDERED ALL INCLUSIVE \*\*\*  
ALL GRAPHICS PROVIDED ARE FOR REFERENCE ONLY. IF CERTAIN DIMENSIONS ARE CRITICAL PLEASE VERIFY THOSE DIMENSIONS WITH YOUR SALESPERSON

Technical drawing showing front, side, and detail views of the ladder. Dimensions include: 23 5/8" (step depth), 32 1/8" (handrail height), 104 11/16" (retracted height), 92 1/8" (mezzanine height), 60" (mezzanine height), 7" (step depth), 58° (angle), 24 3/8" (width), 35 1/4" (width), 3 3/8" (width), and 42 7/16" (extended length).

APPROX WEIGHT: 382.17 lbs.  
DOES NOT INCLUDE WEIGHT OF POWER OR PACKAGING!!!

**STANDARD FEATURES**  
 MODEL NUMBER: LAD-FM-60-PSO  
 STEP DEPTH: 7"  
 OVERALL WIDTH: 35 1/4"  
 STEP HEIGHT: 8 9/16"  
 HANDRAIL HEIGHT: 32 1/8"  
 MEZZANINE HEIGHT: 60"  
 EXTENDED HEIGHT: 92 1/8"  
 EXTENDED LENGTH: 42 7/16"  
 RETRACTED HEIGHT: 104 11/16" (APPROX.)  
 STEP MATERIAL: SERRATED STEEL  
 MAX CAPACITY: 350 LBS.  
 115VAC PWR CABLE HOIST  
 TOUGH BAKED IN POWDER COATED BLUE AND YELLOW FINISH

IT IS THE CUSTOMER'S RESPONSIBILITY TO MAKE SURE THAT THIS UNIT COMPLIES WITH ALL LOCAL SAFETY LAWS, CODES AND REGULATIONS

**SPECIAL FEATURES**  
 NONE

MEZZANINE SHOWN FOR REFERENCE ONLY -NOT INCLUDED

DIMENSION TOLERANCE ± 1/4"

**APPROVAL**

I, THE UNDERSIGNED, AGREE THAT THE PRODUCT AS REPRESENTED SATISFIES DESIGN AND DIMENSION REQUIREMENTS. I ALSO ACKNOWLEDGE MY DUTY TO CONFIRM PRODUCT AND INSTALLATION COMPLIANCE WITH ALL APPLICABLE FEDERAL, STATE AND LOCAL REGULATIONS AND STANDARDS.

**UNITS REQUIRING APPROVAL DRAWINGS OR MODIFIED ARE NON-RETURNABLE**

[ ] As drawn [ ] As marked

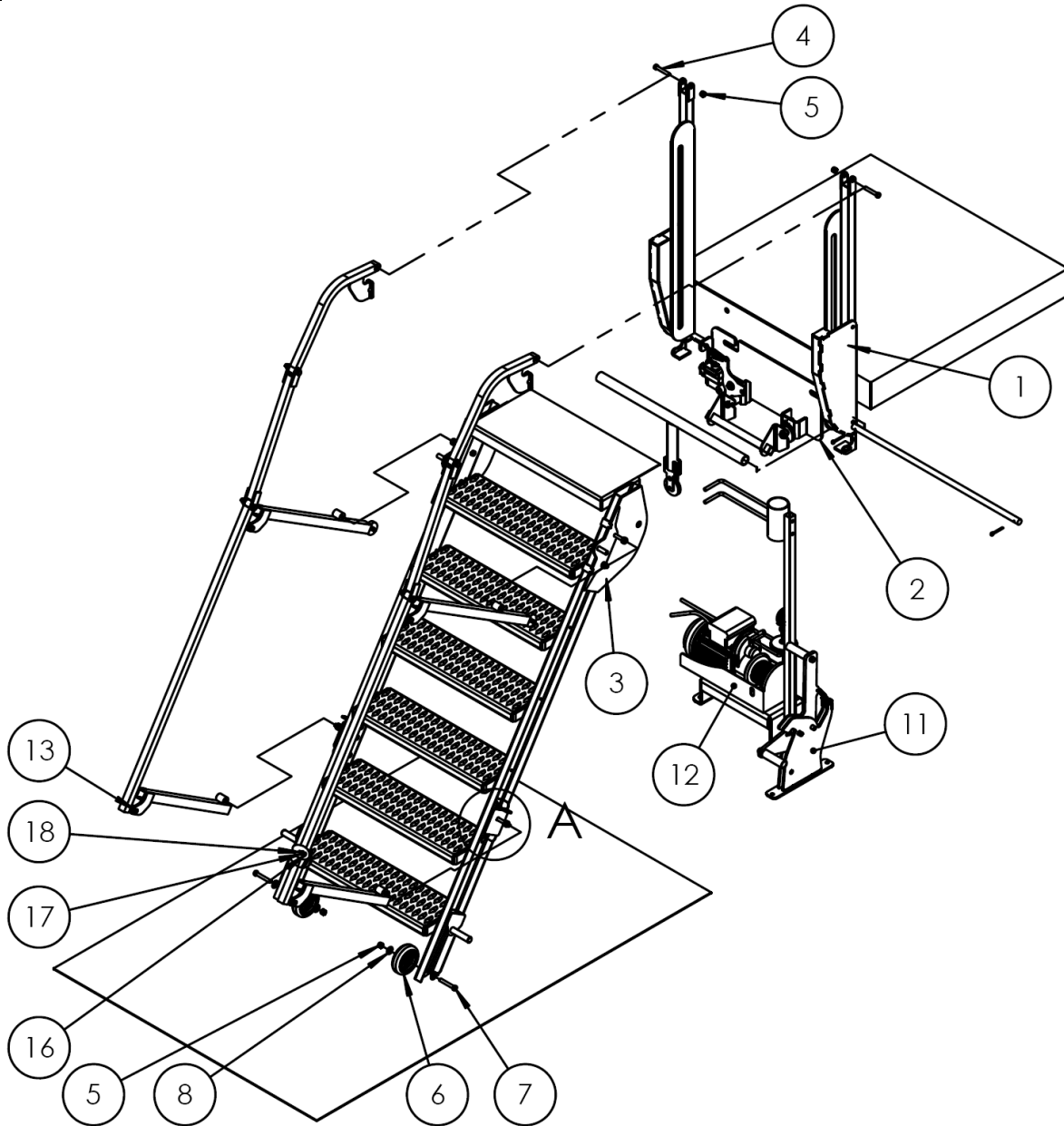
Signed: \_\_\_\_\_ Date: \_\_\_\_\_

Printed Name: \_\_\_\_\_

LEAD TIME WILL START UPON RECEIPT OF SIGNED APPROVAL DRAWING

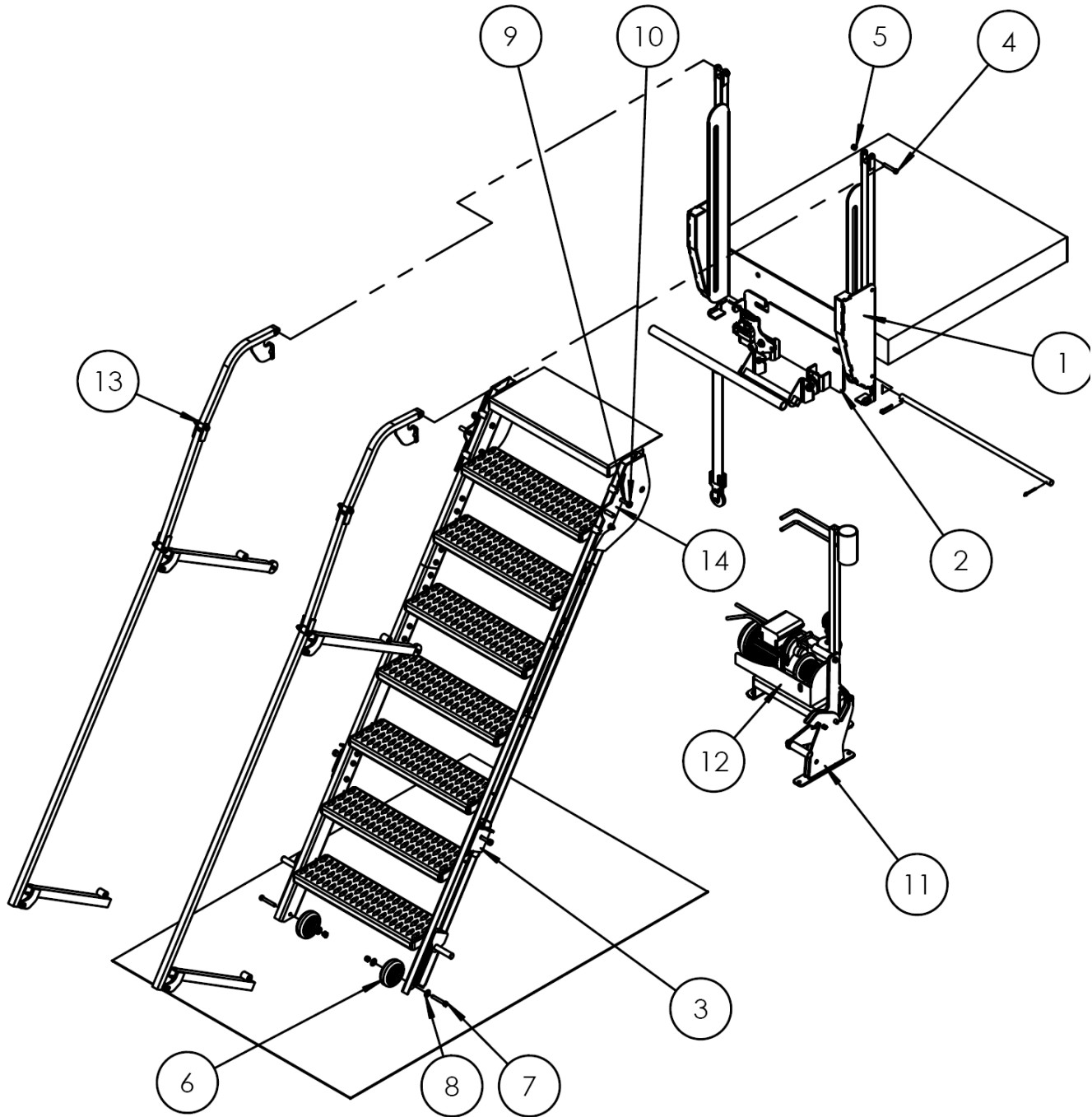
DISTRIBUTOR'S NAME:		P.O.#
VESTIL MANUFACTURING		X
DRAWN BY: NBE	DATE: 4/15/2021	W.O.#
REFERENCE: X	SCALE: 1:32	X
QUOTED LEAD TIME: X	QUOTE # N/A	SALES: X
		FILE NAME: 44-007-710

**FIG. 1: LAD-FM-60 EXPLODED VIEW AND BILL OF MATERIALS (44-006-710)**



Item	Part no.	Description	Qty.	Item	Part no.	Description	Qty.
1	44-516-038	WELDMENT, LADDER MOUNT	1	11	44-537-007	LOCK, FOOT LATCH, STORAGE	1
2	44-514-131	WELDMENT, MOUNTING LIFT BRACKET	1	12	44-514-450	SUB-ASSEMBLY, MINI-CABLE HOIST	1
3	44-514-433	SUB-ASSEMBLY, FRAME	1	13	44-524-209	ASSEMBLY, HANDRAIL	2
4	11112	3/8-16 x 2 1/4 LONG HHCS	2	14	11107	HEX BOLT, GRADE A, ZINC FINISH, 3/8"-16 x 1-1/4"	4
5	37024	NYLON INSERT LOCK NUT, GRADE 2, ZINC FINISH, 3/8"-16	8	15	33006	FLAT WASHER, ZINC PLATED, USS, Ø5/16"	5
6	16-132-009	PP-4/1.25-W	2	16	27402	RHSMS #8-32 X 1" LG	2
7	11113	HEX BOLT, GRADE A, PLAIN FINISH, 3/8"-16 X 2-1/2"	4	17	33074	SAE FLAT WASHER, Z-PLATED, 3/16" (#10)	4
8	33008	FLAT WASHER, LOW CARBON, USS, ZINC PLATED, 3/8"	4	18	37012	#8-32 NYLOCK NUT Z PLATED	2
9	11118	HEX BOLT, GRADE A, ZINC PLATED, 3/8-16 X 3 3/4"	4	19	44-516-036	BRACKET, WELDMENT, PIVOT MT.	2
10	36206	NUT, 3/8 - 16 JAM NUT, ZINC FINISH	6				

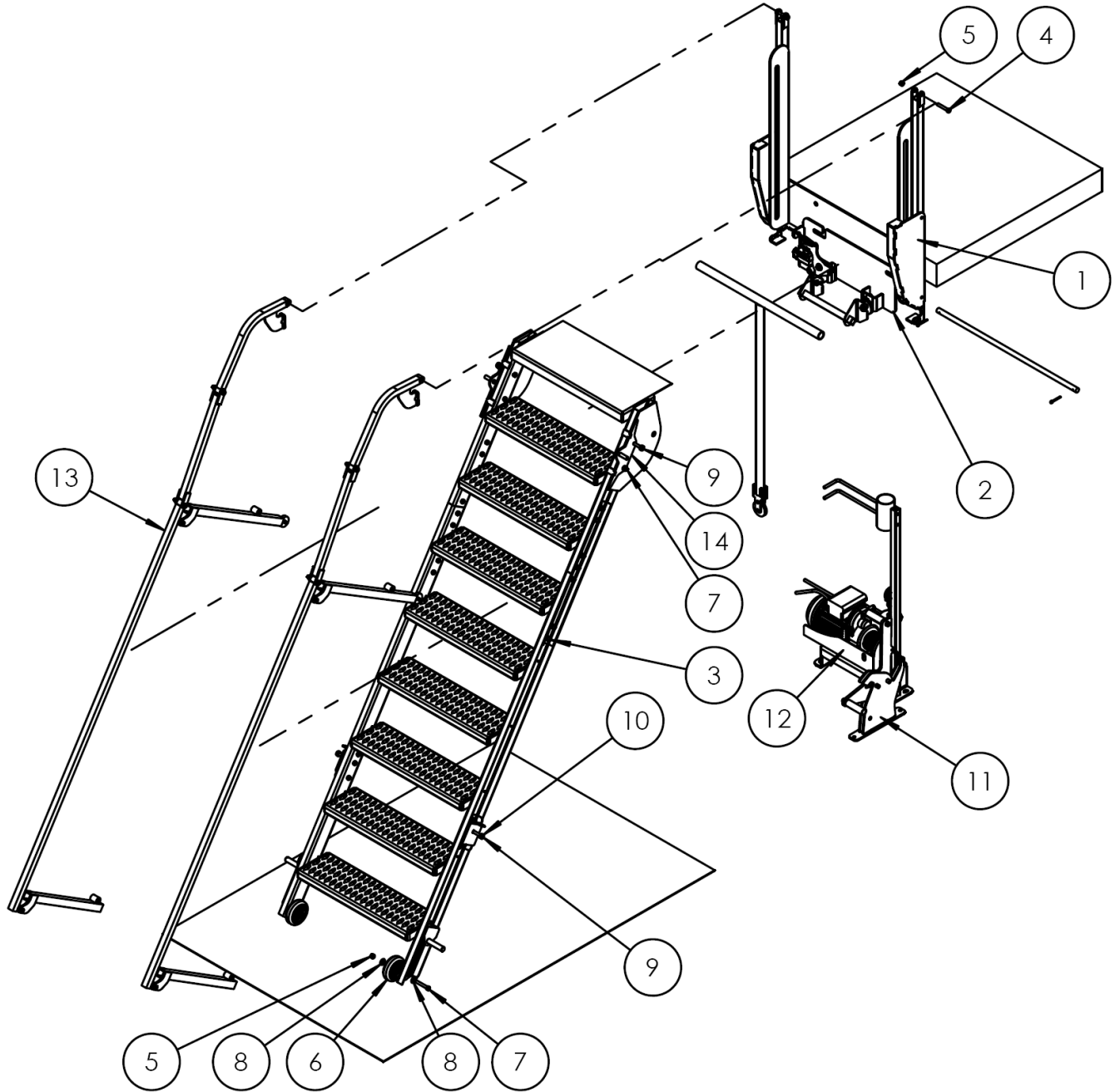
**FIG. 2: LAD-FM-72 EXPLODED VIEW AND BILL OF MATERIALS (44-006-711)**



Item	Part no.	Description	Qty.	Item	Part no.	Description	Qty.
1	44-514-376	Weldment, frame, back assembly	1	8	11113	Hex bolt, gr. A, plain finish, 3/8"-16 x 2 1/2"	10
2	44-514-426	Weldment, frame, step, lower	1	9	37024	Nylock insert lock nut, gr. 2, zinc finish, 3/8"-16	16
3	44-112-010	Pin, main hinge	1	10	33008	Flat washer, low carbon, USS, zinc plated, 3/8"	12
4	16-132-009	4" x 1.25" poly-on-poly wheel, PP-4/1.25-W	2	11	11115	Hex bolt, HHCS, #2, zinc plated, 3/8"-16 x 3"	1
5	44-514-277	Weldment, frame, roller bracket, right	1	12	36106	Hex nut, gr. A, zinc plated, 3/8"-16	1
6	44-016-081	Bracket, handrail mount	4	13	65127	Cotter pin, zinc plated, 3/8" x 2"	2
7	44-524-093	Weldment, handrail hinge, right	1	14	11107	Hex bolt, gr. A, zinc finish, 3/8"-16 x 1 1/4"	2

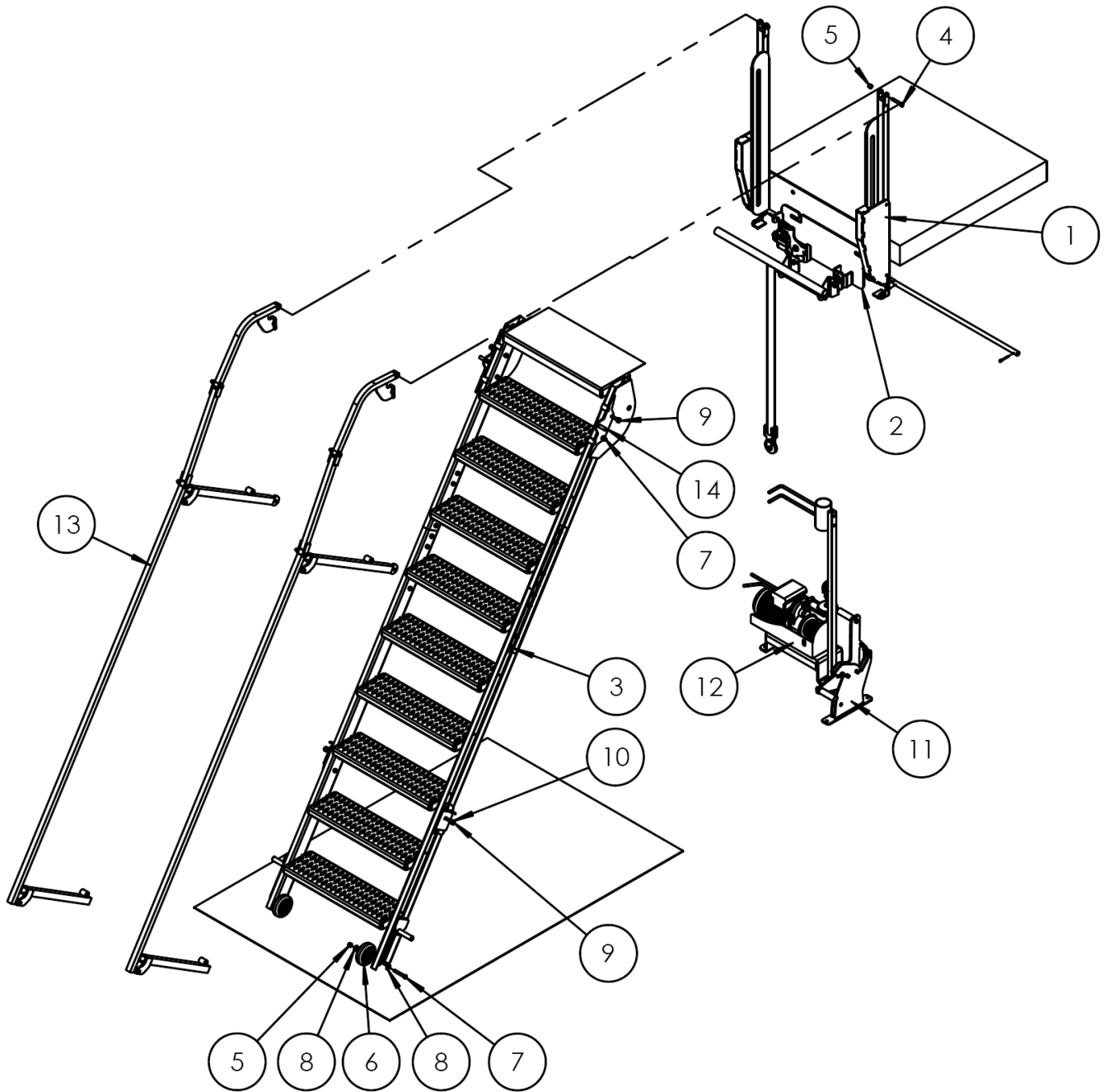


**FIG. 3: LAD-FM-84 EXPLODED VIEW AND BILL OF MATERIALS (44-006-712)**



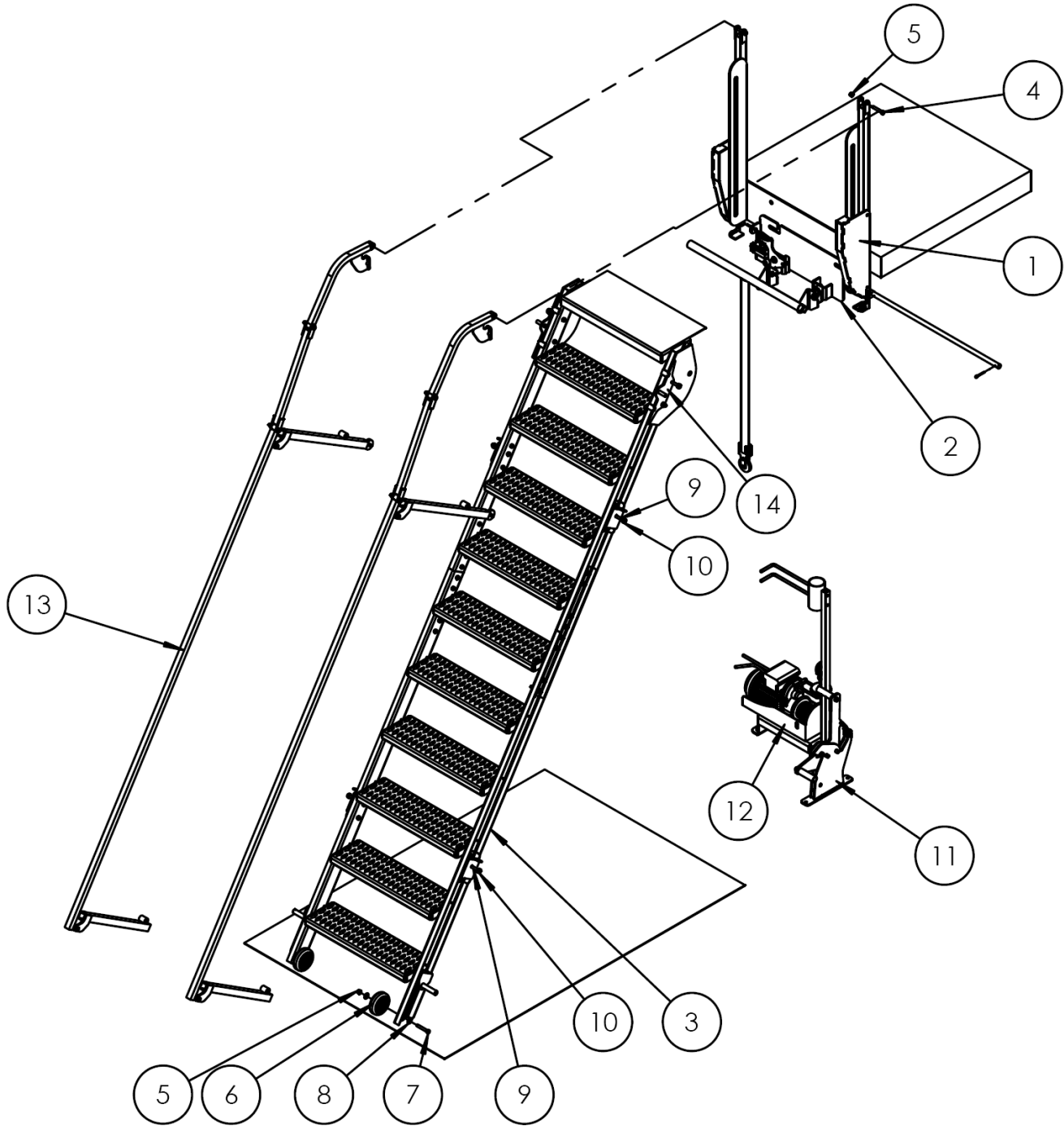
Item	Part no.	Description	Qty.	Item	Part no.	Description	Qty.
1	44-516-032	WELDMENT, LADDER MOUNT	1	8	33008	FLAT WASHER, LOW CARBON, USS, ZINC PLATED, 3/8"	4
2	44-514-131	WELDMENT, MOUNTING LIFT BRACKET	1	9	11118	HEX BOLT, GRADE A, ZINC PLATED, 3/8-16 X 3 3/4"	4
3	44-514-439	SUB-ASSEMBLY, FRAME	1	10	36206	NUT, 3/8 - 16 JAM NUT, ZINC FINISH	6
4	11112	3/8-16 x 2 1/4 LONG HHCS	2	11	44-537-007	LOCK, FOOT LATCH, STORAGE	1
5	37024	NYLON INSERT LOCK NUT, GRADE 2, ZINC FINISH, 3/8"-16	4	12	44-514-450	SUB-ASSEMBLY, MINI-CABLE HOIST	1
6	16-132-009	PP-4/1.25-W	2	13	44-524-200	ASSEMBLY, HANDRAIL	2
7	11113	HEX BOLT, GRADE A, PLAIN FINISH, 3/8"-16 X 2-1/2"	4	14	44-516-036	BRACKET, WELDMENT, PIVOT MT.	2

**FIG. 4: LAD-FM-96 EXPLODED VIEW AND BILL OF MATERIALS (44-006-713)**



Item	Part no.	Description	Qty.	Item	Part no.	Description	Qty.
1	44-516-032	WELDMENT, LADDER MOUNT	1	8	33008	FLAT WASHER, LOW CARBON, USS, ZINC PLATED, 3/8"	4
2	44-514-131	WELDMENT, MOUNTING LIFT BRACKET	1	9	11118	HEX BOLT, GRADE A, ZINC PLATED, 3/8-16 X 3 3/4"	4
3	44-514-442	SUB-ASSEMBLY, FRAME	1	10	36206	NUT, 3/8 - 16 JAM NUT, ZINC FINISH	6
4	11112	3/8-16 x 2 1/4 LONG HHCS	2	11	44-537-007	LOCK, FOOT LATCH, STORAGE	1
5	37024	NYLON INSERT LOCK NUT, GRADE 2, ZINC FINISH, 3/8"-16	4	12	44-514-450	SUB-ASSEMBLY, MINI-CABLE HOIST	1
6	16-132-009	PP-4/1.25-W	2	13	44-524-201	ASSEMBLY, HANDRAIL	2
7	11113	HEX BOLT, GRADE A, PLAIN FINISH, 3/8"-16 X 2-1/2"	4	14	44-516-036	BRACKET, WELDMENT, PIVOT MT.	2

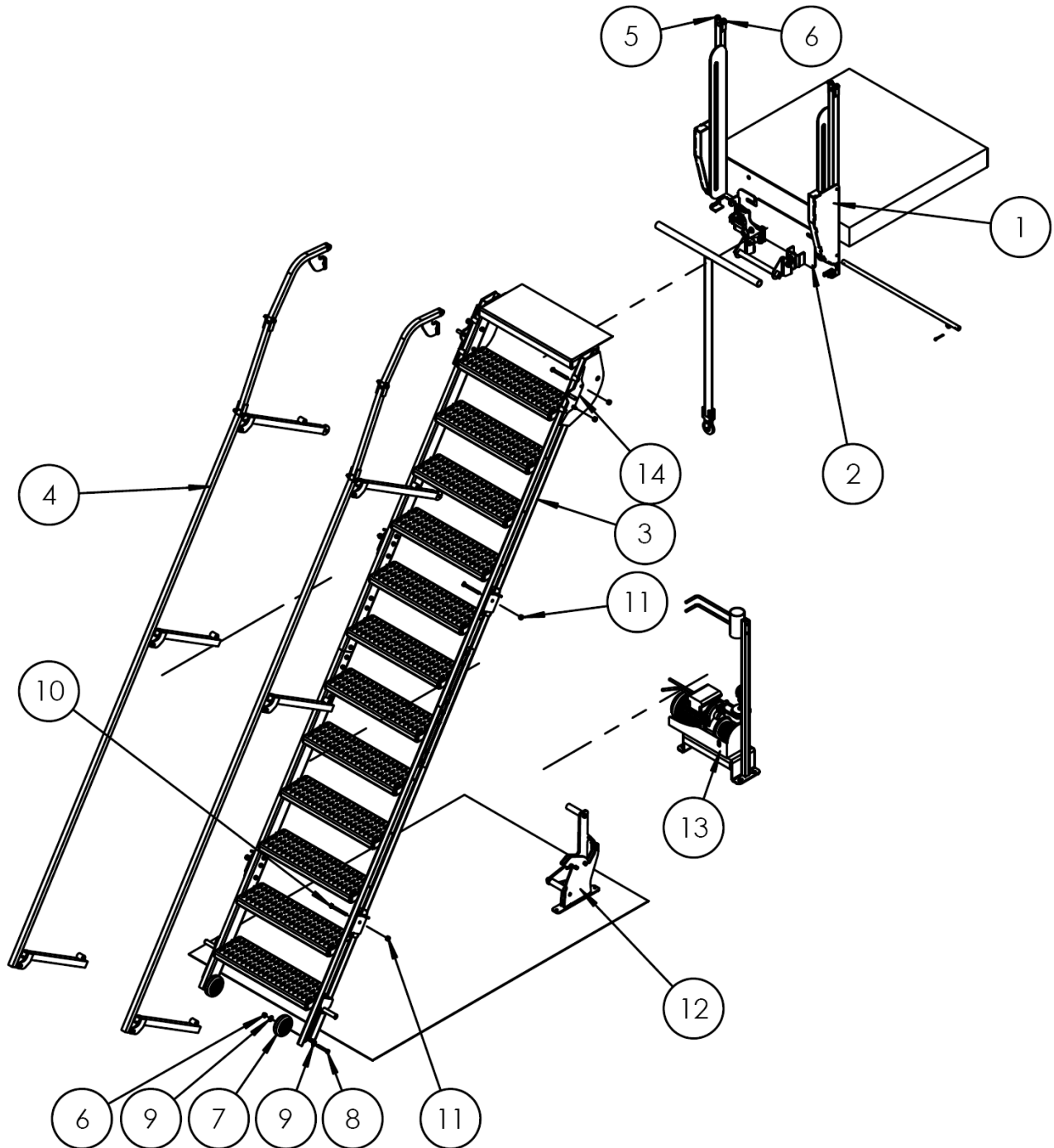
**FIG. 5: LAD-FM-108 EXPLODED VIEW AND BILL OF MATERIALS (44-006-714)**



Item	Part no.	Description	Qty.	Item	Part no.	Description	Qty.
1	44-516-032	WELDMENT, LADDER MOUNT	1	8	33008	FLAT WASHER, LOW CARBON, USS, ZINC PLATED, 3/8"	4
2	44-514-131	WELDMENT, MOUNTING LIFT BRACKET	1	9	11118	HEX BOLT, GRADE A, ZINC PLATED, 3/8-16 X 3 3/4"	6
3	44-514-445	SUB-ASSEMBLY, FRAME	1	10	36206	NUT, 3/8 - 16 JAM NUT, ZINC FINISH	8
4	11112	3/8-16 x 2 1/4 LONG HHCS	2	11	44-537-007	LOCK, FOOT LATCH, STORAGE	1
5	37024	NYLON INSERT LOCK NUT, GRADE 2, ZINC FINISH, 3/8"-16	4	12	44-514-450	SUB-ASSEMBLY, MINI-CABLE HOIST	1
6	16-132-009	PP-4/1.25-W	2	13	44-524-203	ASSEMBLY, HANDRAIL	2
7	11113	HEX BOLT, GRADE A, PLAIN FINISH, 3/8"-16 X 2-1/2"	4	14	44-516-036	BRACKET, WELDMENT, PIVOT MT.	2

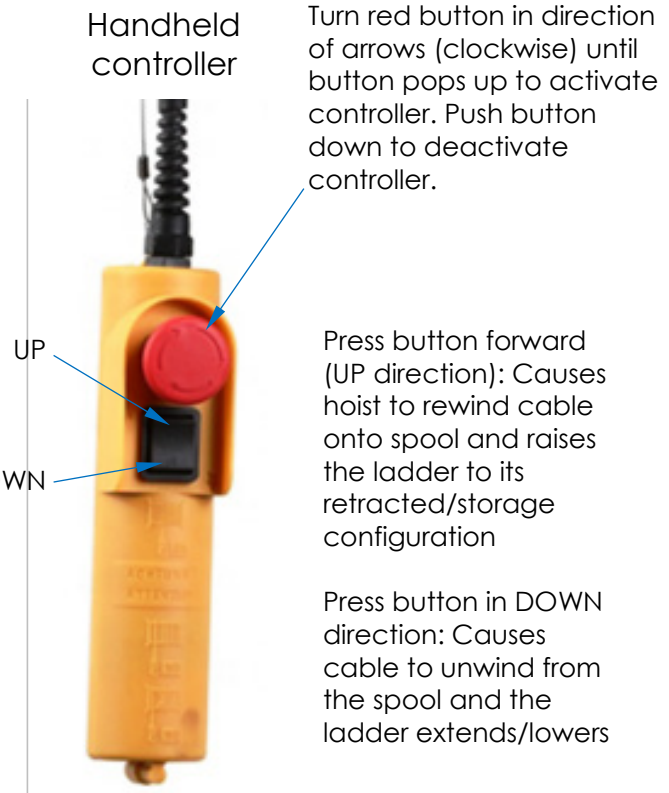
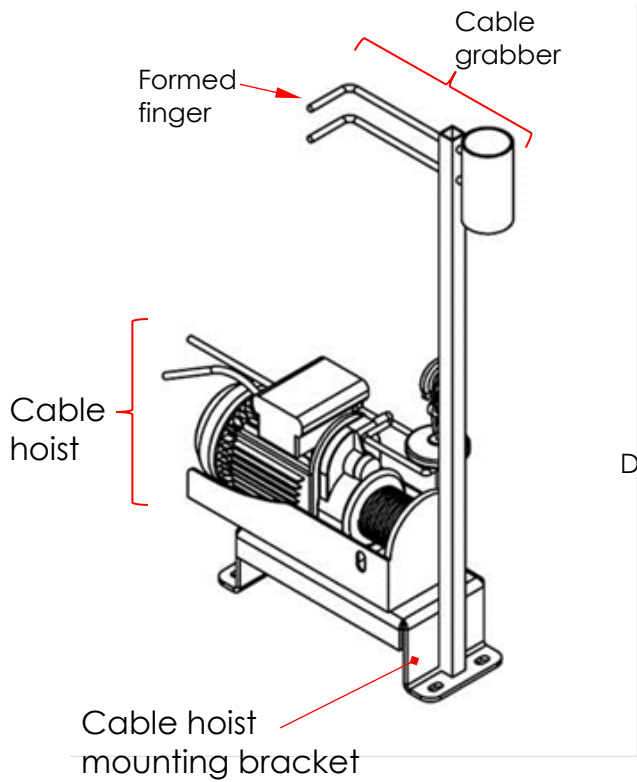


**FIG. 6: LAD-FM-120 EXPLODED VIEW AND BILL OF MATERIALS (44-006-715)**



Item	Part no.	Description	Qty.	Item	Part no.	Description	Qty.
1	44-516-032	WELDMENT, LADDER MOUNT	1	8	11113	HEX BOLT, GRADE A, PLAIN FINISH, 3/8"-16 X 2-1/2"	4
2	44-514-131	WELDMENT, MOUNTING LIFT BRACKET	1	9	33008	FLAT WASHER, LOW CARBON, USS, ZINC PLATED, 3/8"	4
3	44-514-448	SUB-ASSEMBLY, FRAME, STAIR	1	10	11118	HEX BOLT, GRADE A, ZINC PLATED, 3/8-16 X 3 3/4"	6
4	44-524-205	ASSEMBLY, HANDRAIL	2	11	36206	NUT, 3/8 - 16 JAM NUT, ZINC FINISH	8
5	11112	3/8-16 x 2 1/4 LONG HHCS	2	12	44-537-007	LOCK, FOOT LATCH, STORAGE	1
6	37024	NYLON INSERT LOCK NUT, GRADE 2, ZINC FINISH, 3/8"-16	4	13	44-514-450	SUB-ASSEMBLY, MINI-CABLE HOIST	1
7	16-132-009	PP-4/1.25-W	2	14	44-516-036	BRACKET, WELDMENT, PIVOT MT.	2

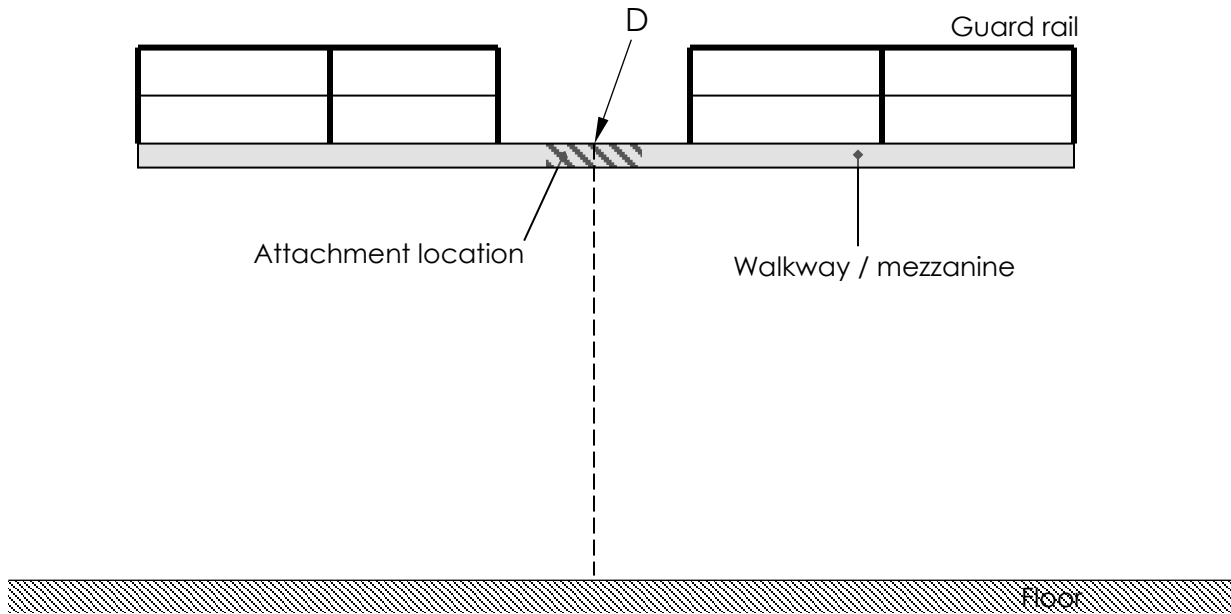
### FIG. 7: CABLE HOIST, MOUNTING BRACKET, CABLE GRABBER AND HANDHELD CONTROLLER



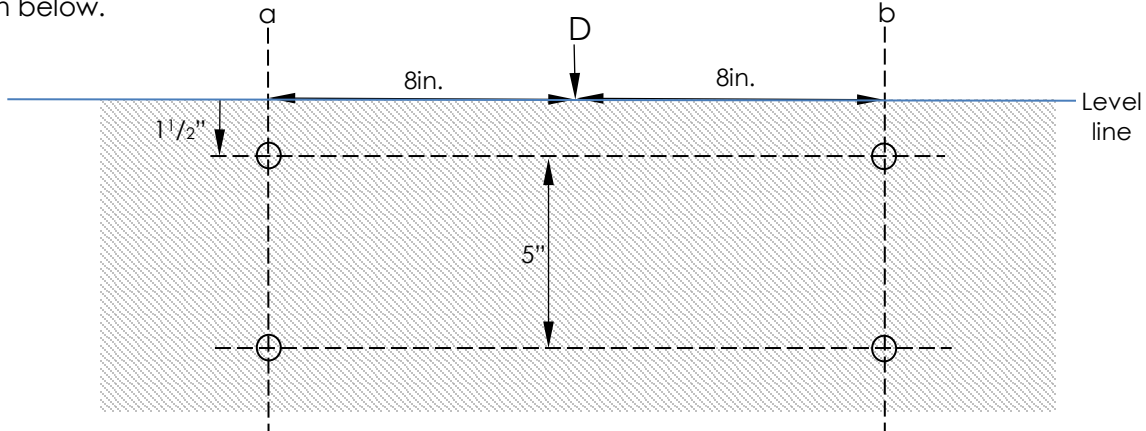
### ASSEMBLY & INSTALLATION

This folding mezzanine ladder system must be fastened securely to a wall or a walkway capable of supporting AT LEAST the combined weight of the stairway plus a full capacity load of 350 pounds (159kg). Refer to your [SPECIFICATIONS](#) document for the net weight of your ladder system.

Step 1: Select the location where the stairs will be installed.

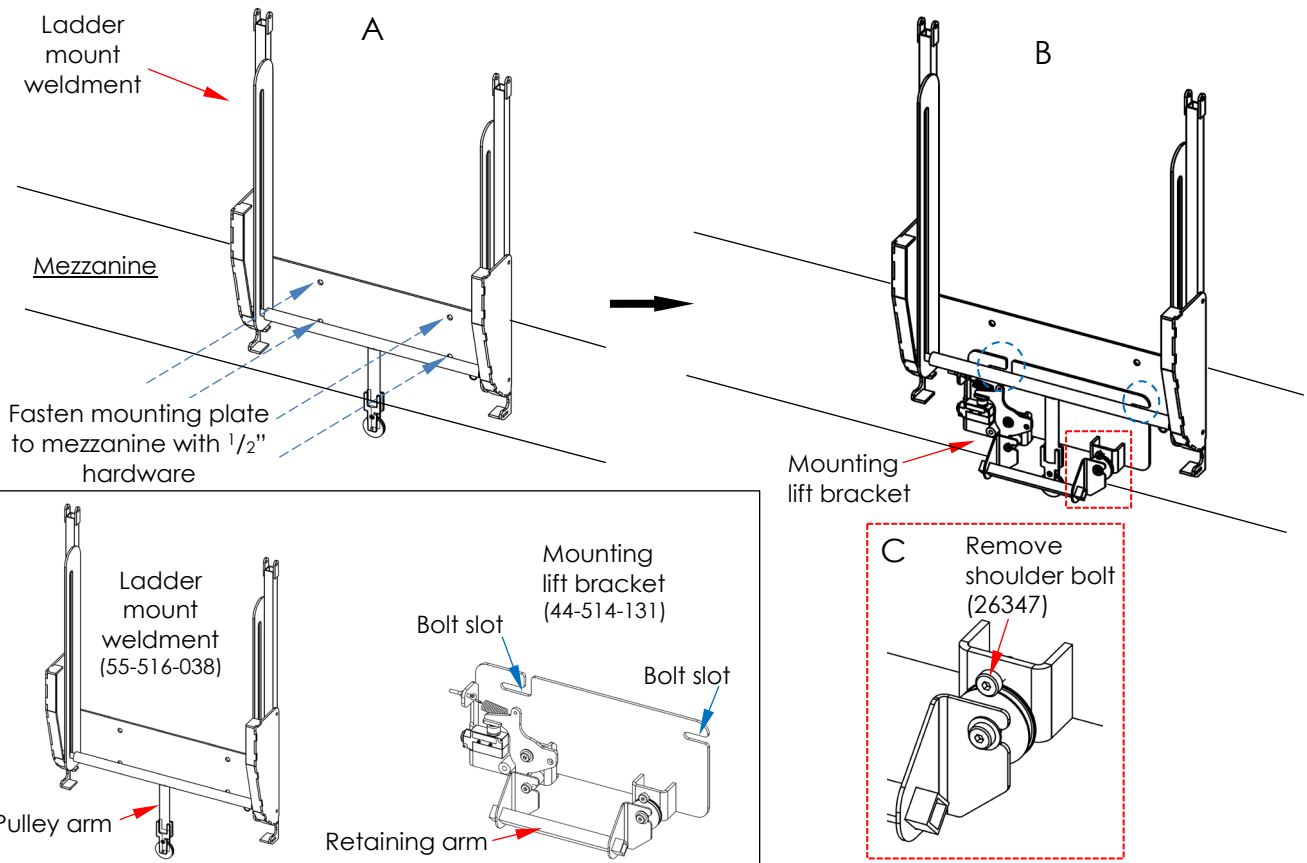


**Step 2:** Use point D as the reference for determining the proper locations of bolt holes. The holes drilled into the face of the mezzanine/walkway must match the relative locations of bolt holes in the center mounting bracket (44-016-138) of the ladder mount weldment (44-516-038). Dimensions are shown below.

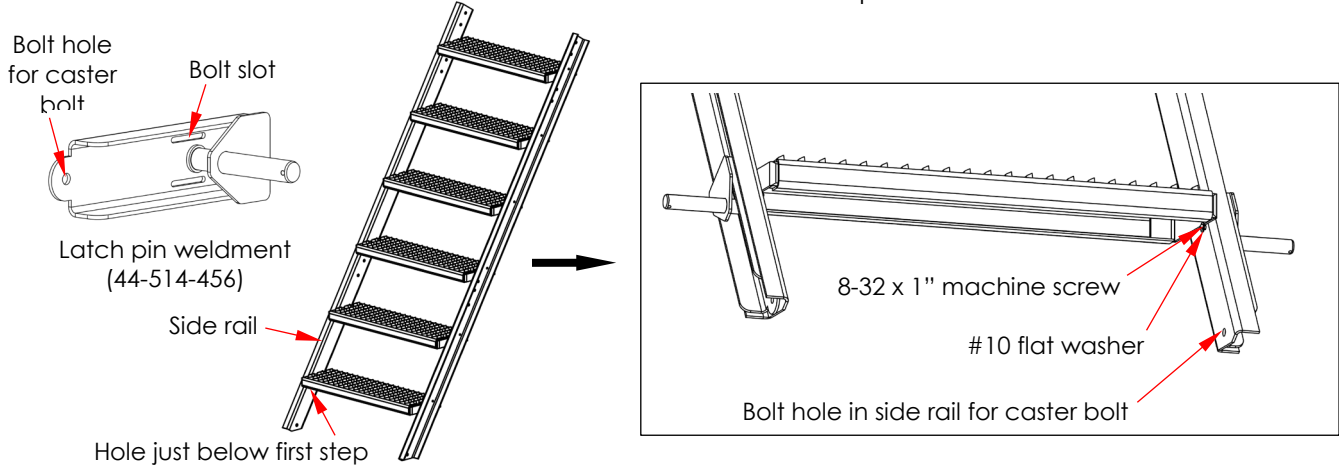


Make a line that extends 8" on both sides of point D on the wall or mezzanine. The line must be parallel to the floor. Next, draw a plumb line at both 8" marks (lines are labeled "a" and "b" in the diagram above). Mark each plumb line 1 1/2" and 6 1/2" below the level line. Bolt holes will be drilled at all four points as shown above. The pre-drilled holes in the mounting frame are 5/8" (diameter). We recommend using 1/2" (diameter) fasteners to connect the mounting plate to the wall or mezzanine. Your building engineer should select hardware appropriate for the wall or mezzanine material and of suitable length.

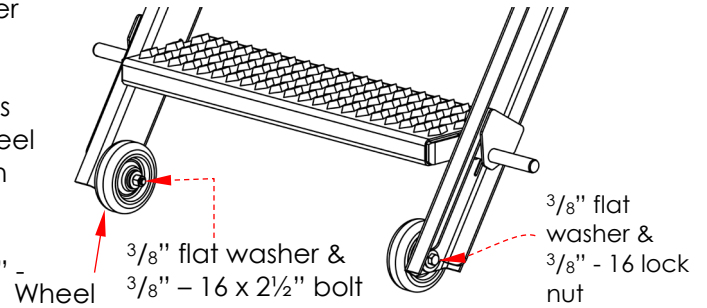
**Step 3:** A) Fasten the ladder mount weldment (44-516-038) to the mezzanine using the 1/2" bolts selected by your building engineer. Install but do not tighten the two bottom bolts. B) Align the bolt slots in the mounting lift bracket (44-514-131) with the lower bolts (circled); then tighten the bolts. The pulley arm must be inside the mounting lift bracket behind the retaining bar. C) Remove the shoulder bolt shown in figure C.



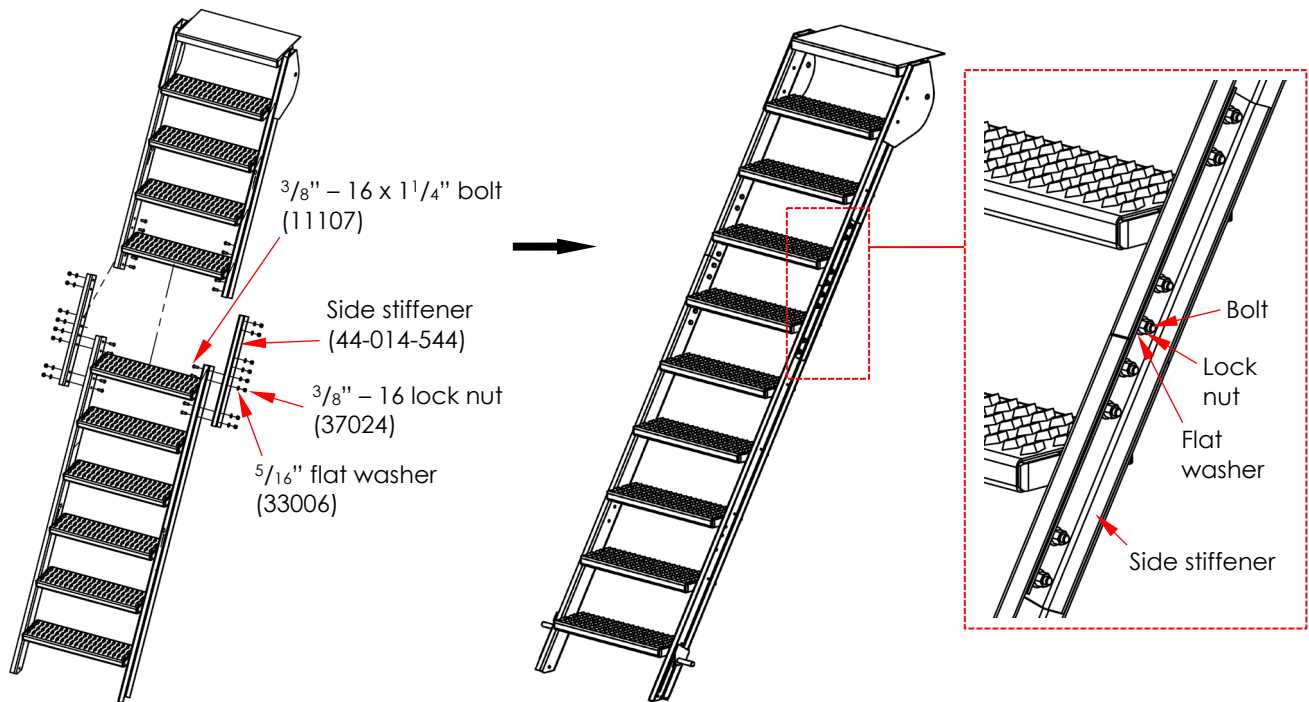
**Step 4:** Install a latch pin weldment (44-514-456) near the bottom of each side rail of the lower step weldment (6 steps; 44-514-441). Attach each latch pin weldment to a side rail with an 8-32 x 1" round head machine screw (27402). Slide a #10 flat washer onto each screw. Insert a screw through the hole in a side rail just beneath the first step and then through the matching bolt slot in the latch pin weldment. Install another #10 flat washer onto the end of each screw. Install an 8-32 lock nut (37012) on each screw. Leave the connections loose until wheels are installed in Step 5.



**Step 5:** Attach the wheels to the side rails of the lower step weldment. [NOTE: Models LAD-FM-60 and LAD-FM-72 just have 1 step weldment.] Slide a 3/8" flat washer (33008) onto each of two 3/8" - 16 x 2 1/2" bolts (11113). Insert a bolt through the center of each wheel (16-132-009), through the hole in the bottom of each side rail, and finally through the bolt hole in the bottom of the corresponding latch pin weldment. Secure each bolt with another flat washer and a 3/8" - 16 lock nut (37024).

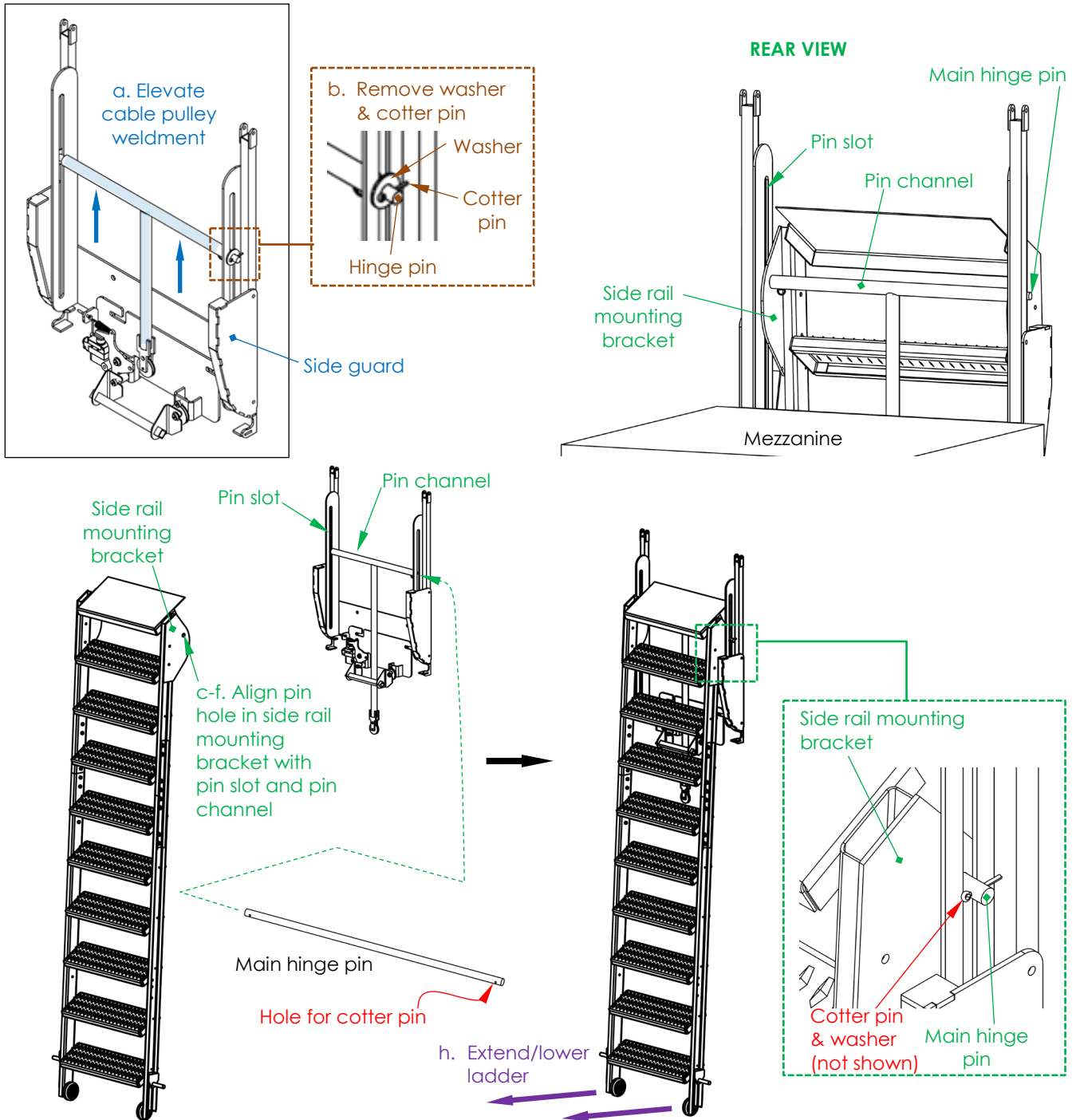


**Step 6:** [This assembly step does not apply to models LAD-FM-60-PSO or LAD-FM-72-PSO.] Assemble the stairs. Fasten the top step weldment to the lower step weldment using 2 side stiffeners and 3/8" hardware as shown in the diagrams.



**Step 7:** Fasten the stairway to the ladder mount weldment.

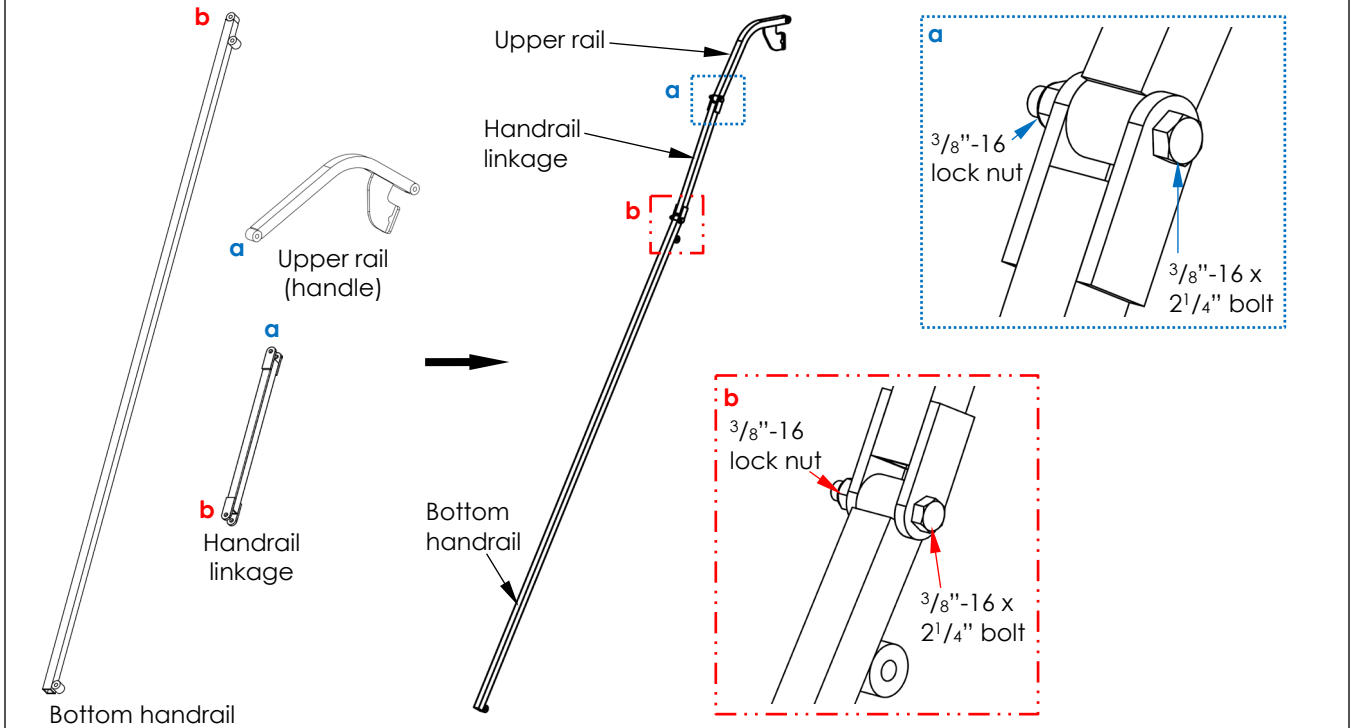
- a. Manually elevate the T-shaped cable pulley weldment until the main hinge pin (44-112-010) is accessible above the side guards.
- b. Remove one or both of the washers and cotter pins (65127) from the hinge pin; then extract the hinge pin.
- c. Lift the top end of the stairway, e.g. with a hoist or a fork truck.
- d. Align the pin holes in the side rail mounting brackets with the pin slots in the ladder mount bracket.
- e. Align the hinge pin channel (of the cable pulley weldment) with the pin holes in the side rail mounting brackets.
- f. Insert the main hinge pin through the pin slots, the side rail mounting brackets, and the pulley weldment.
- g. Reinstall the cotter pin(s) and washer(s) removed in step b.



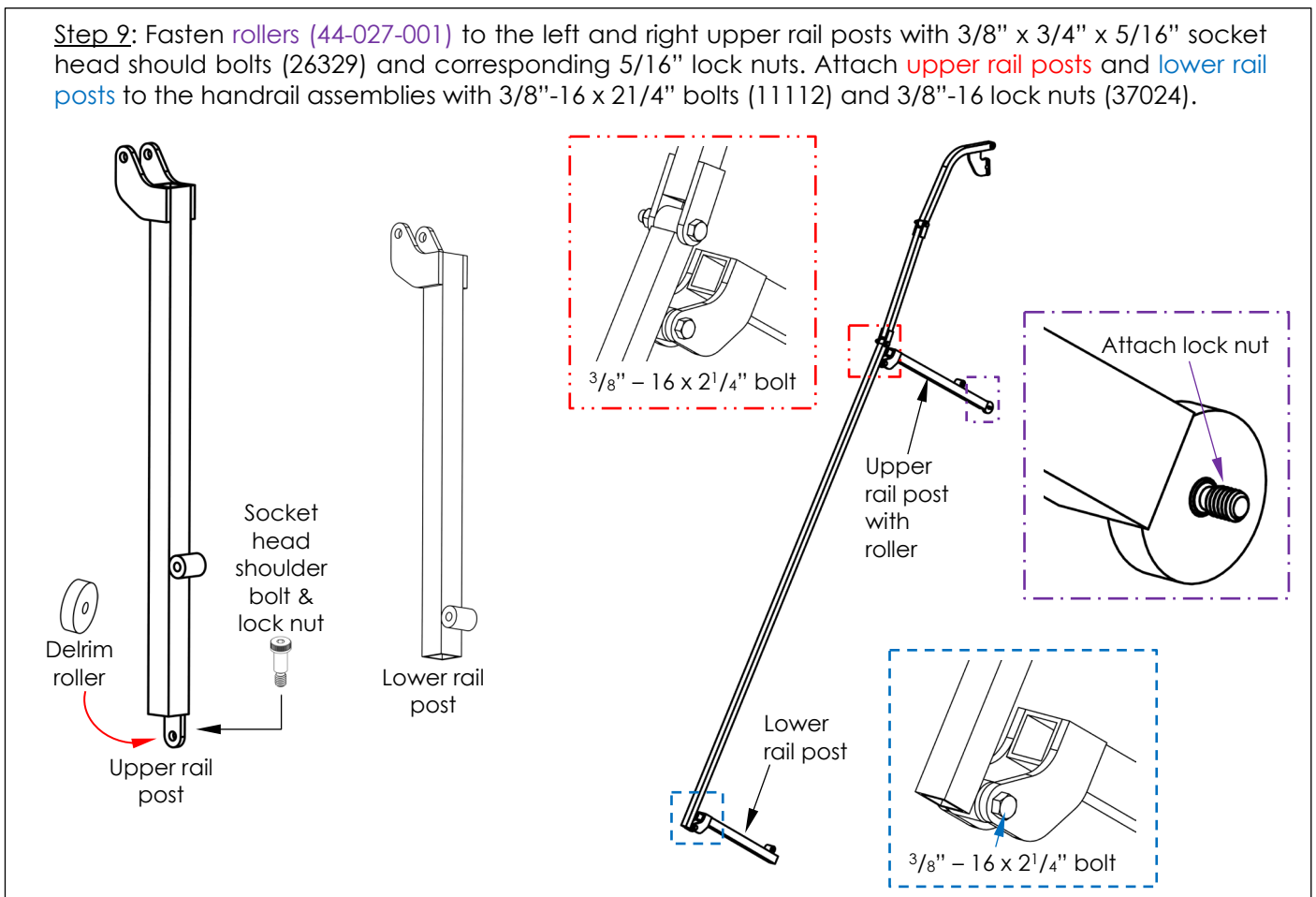
- h. Carefully extend the ladder by controlling the base of the ladder as it rolls away from the mezzanine. Fully extend the ladder so that the hinge pin rests on the bottoms of the pin slots



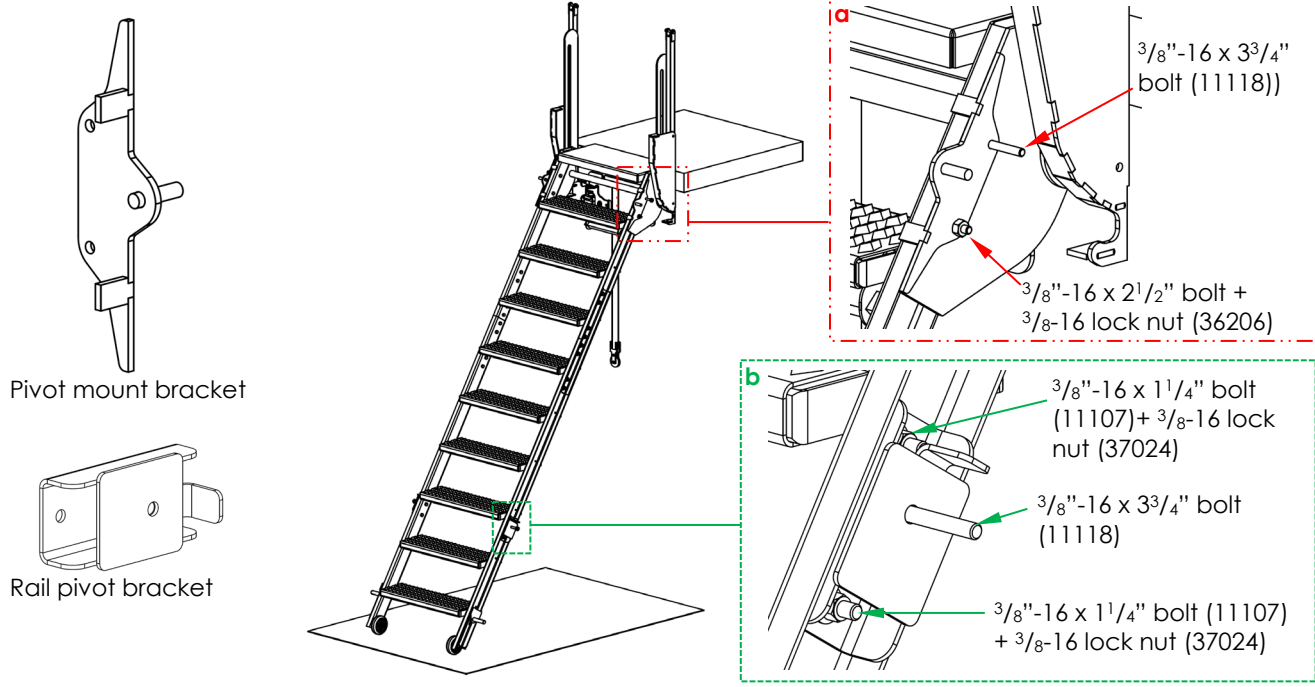
**Step 8:** Assemble the handrails. Each handrail consists of 3 pieces: Upper rail (handle); handrail linkage; and bottom handrail. Attach the handrail segments together with 3/8"-16 x 2 1/4" bolts (11112) and 3/8"-16 lock nuts (37024). Attach end **a** of the upper rail to end **a** of the handrail linkage; attach end **b** of the bottom handrail to end **b** of the handrail linkage.



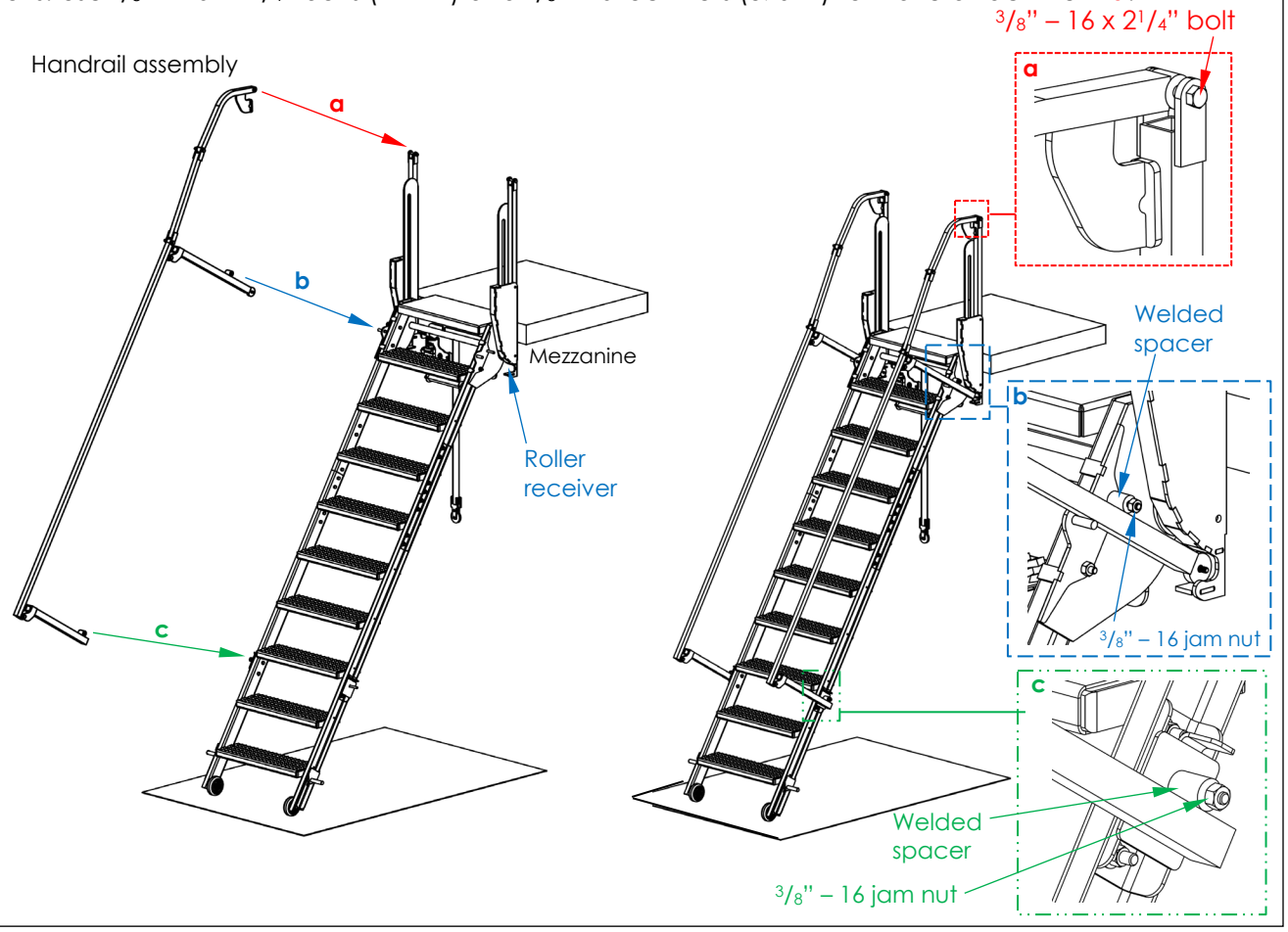
**Step 9:** Fasten rollers (44-027-001) to the left and right upper rail posts with 3/8" x 3/4" x 5/16" socket head shoulder bolts (26329) and corresponding 5/16" lock nuts. Attach upper rail posts and lower rail posts to the handrail assemblies with 3/8"-16 x 2 1/4" bolts (11112) and 3/8"-16 lock nuts (37024).



Step 10: **a)** Attach a pivot mount bracket (44-516-036) to each of the side rail mounting brackets as shown in the following diagram. **b)** Attach a rail pivot bracket (44-516-035) to each side rail.

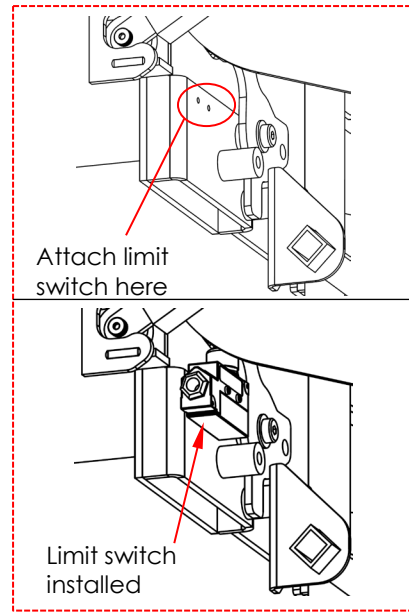
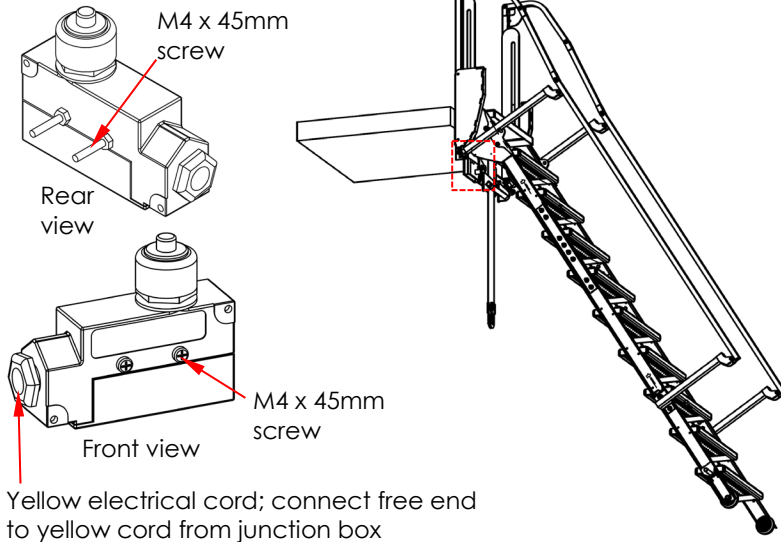


Step 11: Attach the handrail assemblies made in step 9 to the siderails. To make connections **b** and **c**, set rollers on roller receivers and slide the spacers welded onto the upper and lower rail posts onto the  $\frac{3}{8}$ "-16 x  $3\frac{3}{4}$ " bolts installed in the brackets in step 10. Tighten  $\frac{3}{8}$ "-16 jam nuts (36206) on the ends of the bolts. Use  $\frac{3}{8}$ " - 16 x  $2\frac{1}{4}$ " bolts (11112) and  $\frac{3}{8}$ " -16 lock nuts (37024) to make attachment **a**.

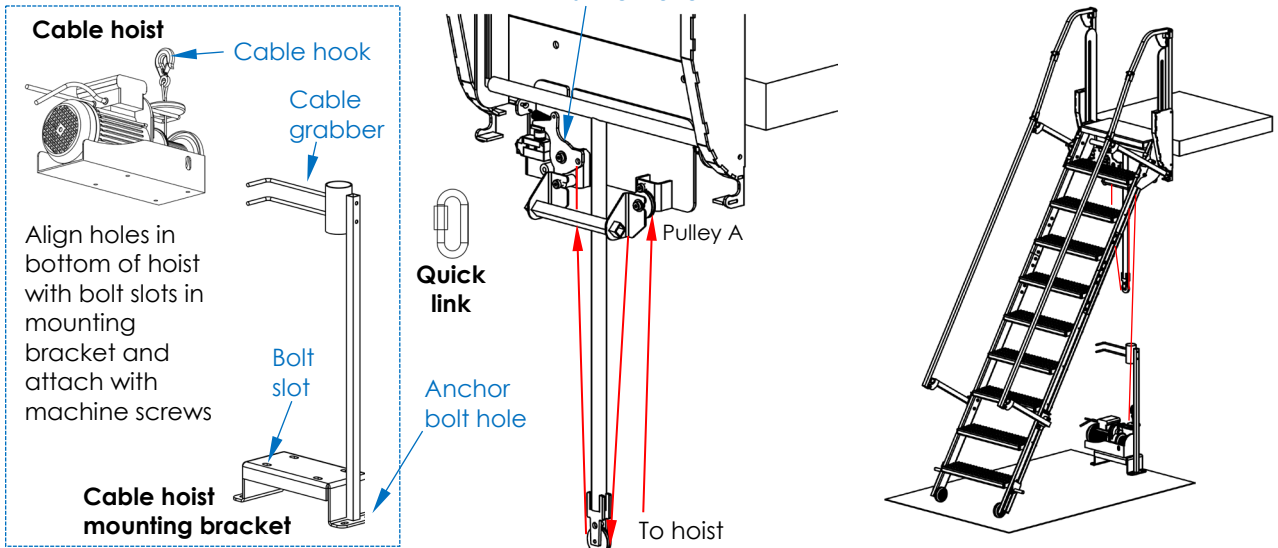


**Step 12:** Attach the limit switch (01-022-021) to the mounting lift bracket. See [Step 3](#) on p. 11. The limit switch is connected to a yellow electrical cord. It attaches to the mounting lift bracket via two (2) M4 x 45mm screws. Attach the free end of the yellow cord from the limit switch to the free end of the yellow cord from the junction box.

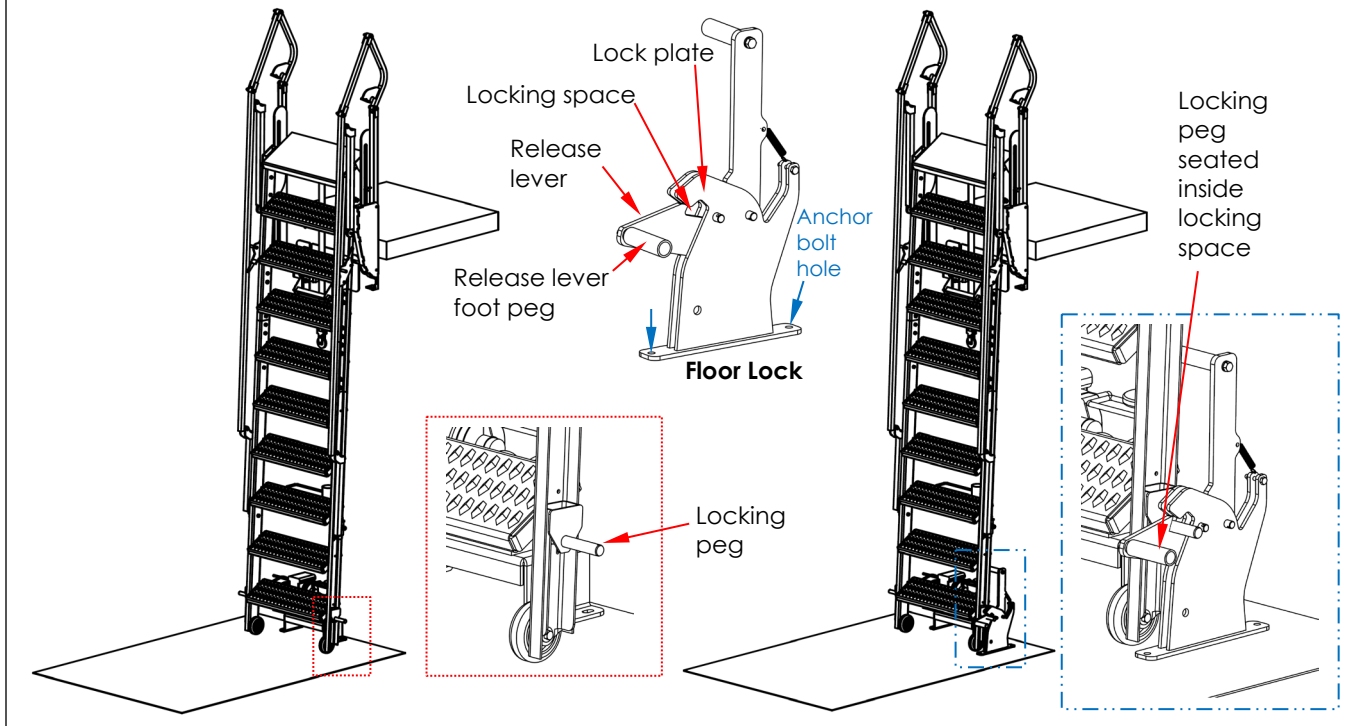
**Limit switch**



**Step 13:** Install the cable hoist. A) The hoist attaches to a formed mounting bracket (44-016-123) with 4 metric machine screws. The screws are wound into bolt holes in the bottom of the winch. Remove the screws. Set the hoist on top of the formed bracket. Align the bolt holes in the bottom of the winch with the bolt slots in the bracket. Install and tighten the screws. B) Connect the winch to the power source. Plug the 3-prong adaptor at the end of the black power cord to a 115VAC power outlet. C) Twist the red button on the handheld controller in the direction of the arrows on the button. The button should pop up. The hoist will now respond to signals from the controller. A 3-position switch is located below the red button on the controller. Pressing the switch forward causes the hoist spool to rotate and cable to unwind from the hoist. Pressing the button back (and down) causes the spool to rotate in the opposite direction which winds cable back onto the spool. Take hold of the cable hook and press the button forward to unwind cable from the spool. Unwind approximately 10-12 feet of cable. D) Attach the cable hook to a quick link (99-145-053). E) Feed cable to the left of the cable grabber (same side as the bent fingers) and into the groove of pulley A. Reinstall the shoulder bolt removed during [Step 3C](#) on p. 11. Then, seat cable into the groove of pulley B. F) Attach the quick link to the small opening on the right side of the limit switch lever (44-016-132). G) Move the hoist to a position where the cable is substantially vertical. Mark the floor with the locations of the anchor bolt holes in the mounting bracket. Attach the bracket to the floor using 3/8" anchor bolts of appropriate length as selected by your building engineer.



**Step 14:** Install the floor lock assembly (44-537-007). Press the 3-way control button forward and raise/retract the ladder to the fully retracted position. Set the floor lock assembly on the floor next to the ladder. Press the release lever down. Move the floor lock assembly to bring the locking peg into the locking space between the release lever and the lock plate. Mark the floor with the locations of the anchor bolt holes on the mounting plate. The bolt holes will accept 3/8" anchor bolts of appropriate length as selected by your building engineer. Drill holes in the locations of the floor marks and install anchoring hardware following the manufacturer's instructions.



## USING THE MEZZANINE LADDER

Review the [SAFETY INSTRUCTIONS](#) on p. 2-3 before using the ladder. Always grasp the handrails and face the ladder when climbing or descending the steps. Inspect the ladder before each use for damage, such as unusual wear, deterioration, or corrosion. Tighten loose nuts. If a lock nut has been partially or completely unfastened, it must be replaced with a new lock nut.

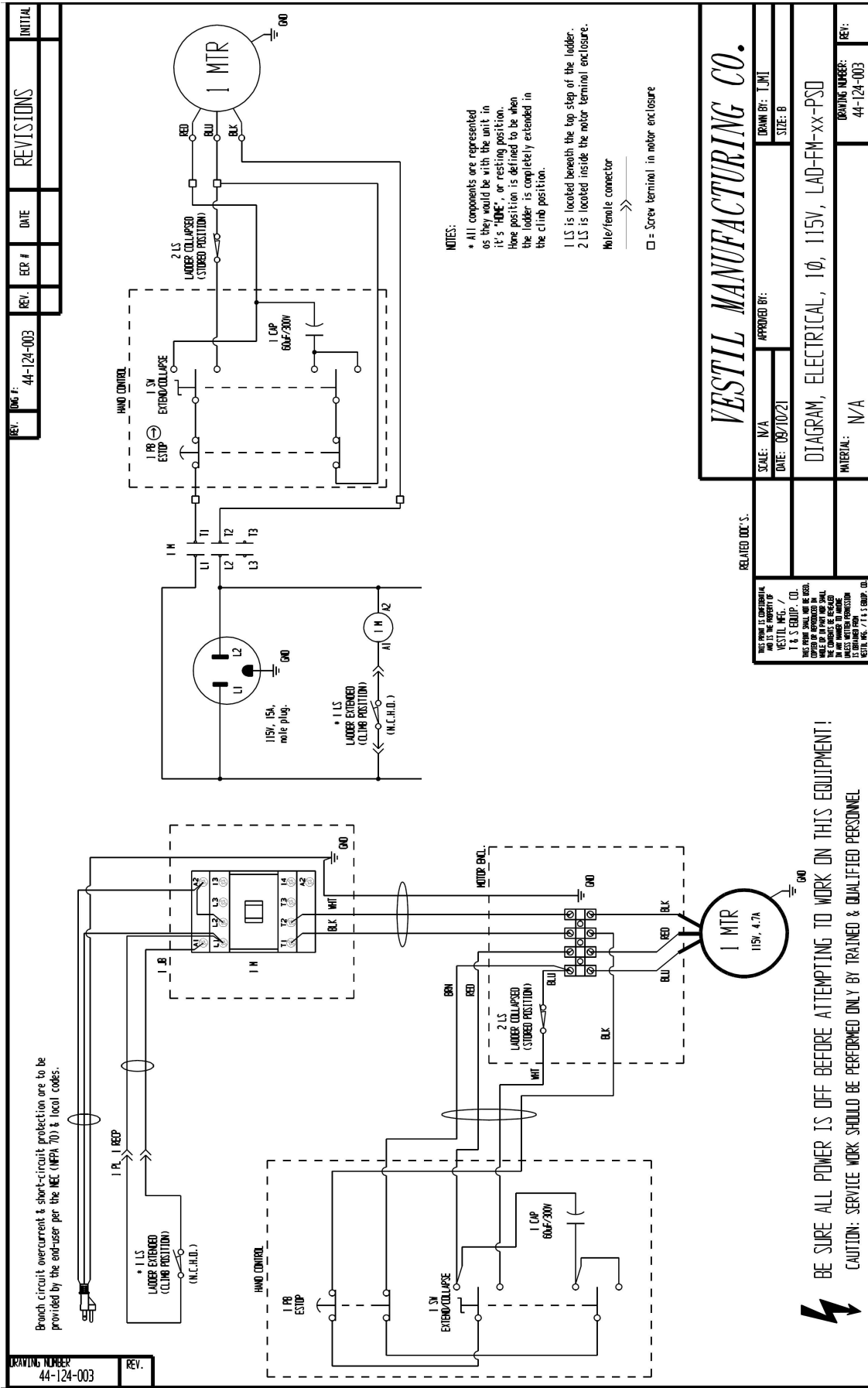
To lower/extend the ladder from the raised/retracted position:

1. Stand beside the ladder at a location where you will avoid contact with it as it lowers but can easily monitor it. Twist the red button on the handheld controller in the direction of the arrows until the button pops up. See [FIG. 7](#) on p. 10.
2. Press down on the release lever foot peg (see [Step 14](#) on p. 17) of the floor lock to release the locking peg (attached near the bottom of the ladder siderail) from the floor lock.
3. Grasp the segment of cable that extends from the hoist to pulley A and pull it toward you until the limit switch lever lifts off of the limit switch. See [Step 13](#) on p.16. The cable can either be pulled by hand or by engaging the cable with the formed fingers of the cable grabber and pulling the cable grabber away from the ladder.
4. Push the 3-way button on the hand control in the DOWN direction. See [FIG. 7](#) on p. 10. Once the ladder begins to move, gently release the cable.
5. Hold the button down until the ladder is completely lowered/extended.
6. Push the red button on the handheld controller down. The controller can be stored in the round tube portion of the cable grabber.

To raise/retract the ladder:

1. Stand to the side of the ladder. Avoid contact with the ladder as it retracts.
2. Twist the red button on the handheld controller until it pops up.
3. Press the UP button on the handheld controller. Hold the button until the ladder retracts completely and the locking peg seats into the floor lock.
4. Press the red button down and set the controller in the cable grabber.

# ELECTRICAL CIRCUIT DIAGRAM (44124003)





## RECORD OF SATISFACTORY CONDITION

After assembling and installing the mezzanine ladder system, and before putting it into service, make a detailed record of its appearance and operation. Include descriptions of the steps, wheels, hardware, handrails, and cable hoist. Describe the connection of the ladder mount weldment to the mezzanine (see [Step 3](#) on p. 11). Operate the cable hoist to extend and retract the ladder. Include observations about the process: how the hoist sounds as it operates; how the main hinge pin slides in the pin slots of the ladder mount weldment; and how the handrails fold, especially the movement of the rollers into and out of the roller receivers (see [Step 11](#) on p. 15). Thoroughly photograph the ladder from multiple angles. Include photographs of all labels. Collect all writings and photographs in a file. This file is a record of the ladder system in satisfactory condition. Compare the results of all inspections to this *RECORD* to determine if the ladder is in satisfactory condition. Do not use the ladder unless it is in satisfactory condition.

## INSPECTIONS & MAINTENANCE

Tag the ladder "Out of service" before inspecting and/or performing maintenance on it. Inspections and maintenance should only be performed by qualified persons. Compare the results of each inspection to the [RECORD OF SATISFACTORY CONDITION](#). Do not use the ladder unless all parts are in satisfactory condition. Replace parts that are not in satisfactory condition before returning the unit to service. Only use manufacturer-approved replacement parts to restore the unit to satisfactory condition. *Never make temporary repairs of damaged or missing parts. DON'T GUESS! If you have any questions about the condition of your ladder, contact the [TECHNICAL SERVICE](#) department.* The phone number is provided on the cover page of this manual.

Operate the cable hoist to put the ladder in the extended/use position before inspecting, or performing maintenance on, the ladder.

### INSPECTIONS

**Before each use** inspect the ladder for any sustained damage, such as unusual wear, deterioration, or corrosion. Look for loose connections. Tighten all loose connections.

**At least once per month**, inspect the following:

- 1. Steps and siderails:** Examine each step and both siderails for cracks, cracked welds, breaks, significant wear, and rusting/corrosion. Remove rust/corrosion with steel wool or a steel bristle brush. Clean and apply touchup paint to the affected areas.
- 2. Stairway mounting frame (see [Step 3](#) on p. 11):** Inspect the connections to the mezzanine. Make sure that all hardware that attaches the ladder mount weldment to the mezzanine is securely fastened to the mezzanine. Check the bolt holes for elongations, cracks, and corrosion or rusting. Examine the pin slots for bends and damage that affects the travel of the main hinge pin. Remove corrosion. If cracks are found, contact the manufacturer. The pin should slide smoothly and easily within the pin slots as the ladder is extended or retracted.
- 3. Cable hoist and cable hoist mounting bracket (see [FIG. 7](#) on p. 10):** Inspect the bolts slots and the bolt holes in the mounting bracket. Check for elongations, cracks, and corrosion. Examine the hoist cable. Look for frays, birdcaging, cuts, and breaks. Operate the hoist to extend and retract the ladder. Cable should smoothly unwind from, and wind back onto, the hoist spool.
- 4. Floor lock:** Confirm that the lock is solidly anchored to the floor. Make sure that the lock functions properly, i.e. the lock securely traps the locking peg inside the locking space. The spring should automatically bias the lock release lever to the closed position.
- 5. Handrails:** Closely examine all hardware/fasteners. Tighten loose connections. Check the handrails for bends and cracks, particularly connections between handrail segments and connections to handrail posts. Both handrails should be rigid and undamaged. Replace all damaged sections of the handrails before returning the stair system to service.
- 6. Labels:** The ladder should always be labeled as shown in the [LABELING DIAGRAM](#). Replace a label if it is missing, damaged, or not easily readable, e.g. faded.

### MAINTENANCE

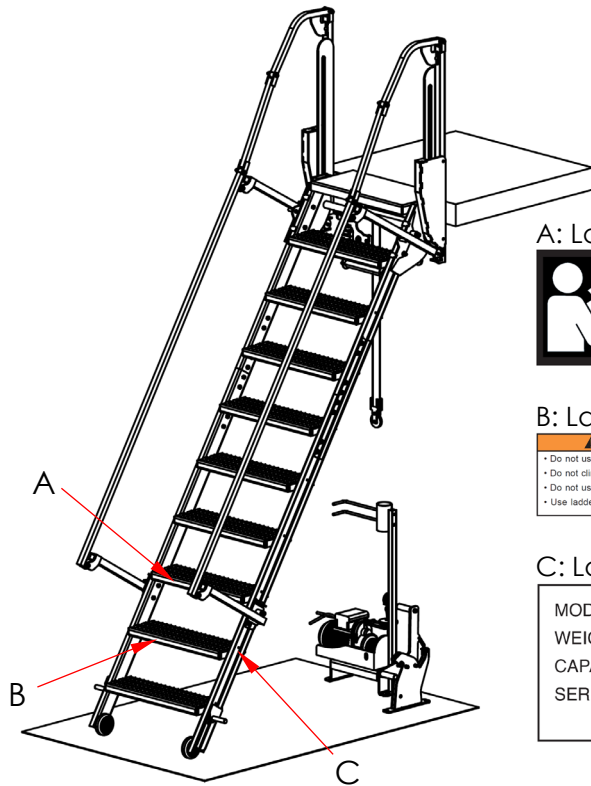
In addition to correcting issues discovered during inspections, maintain the ladder.

- Clean the ladder with a damp cloth to remove dirt and grime, especially from step surfaces. Let the ladder dry completely before returning it to service.

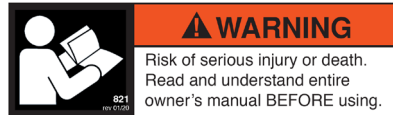
- Lubricate bolts as necessary for the rollers and spacers to rotate freely.
- Apply touchup paint wherever the finish is damaged. Apply touchup paint as soon as damage occurs.

## LABELING DIAGRAM

Each unit should be labeled as shown in the diagram. However, label content and locations are subject to change so your product might not be labeled exactly as shown. Compare the diagram below to your [RECORD OF SATISFACTORY CONDITION](#). If there are any differences between actual labeling and this diagram, adapt the diagram to reflect actual labeling. Replace all labels that are damaged, missing, or not easily readable (e.g. faded). To order replacement labels or to inquire whether your unit is properly labeled, contact the technical service and parts department online at [http://www.vestilmfg.com/parts\\_info.htm](http://www.vestilmfg.com/parts_info.htm) or by calling (260) 665-7586 and asking for the Parts Department.



A: Label 821



B: Label 740

⚠ WARNING	⚠ ADVERTENCIA	⚠ AVERTISSEMENT
<ul style="list-style-type: none"> <li>• Do not use near live electric lines</li> <li>• Do not climb rails or lean over rails</li> <li>• Do not use if damaged or worn</li> <li>• Use ladder on level, smooth surfaces only</li> </ul>	<ul style="list-style-type: none"> <li>• No use cerca de líneas eléctricas</li> <li>• No se suba o se asome en la barandilla</li> <li>• No use si esta danado o gastado</li> <li>• Use la escalera en superficies a nivel y lisas</li> </ul>	<ul style="list-style-type: none"> <li>• Ne pas utiliser près des lignes électriques sous tension</li> <li>• Ne pas grimper sur ou vous pencher des rails</li> <li>• Ne pas utiliser si endommagée ou usagée</li> <li>• Utiliser l'échelle seulement sur des surfaces plates et lisses</li> </ul>

C: Label 1153

MODEL / MODÉLO / MODÈLE _____
WEIGHT / PESO / MASS _____
CAPACITY / CAPACIDAD / CAPACITÉ _____
SERIAL / SERIE / SÉRIE _____
UNITS: 2.2 lb. = 1kg      1" (or 1in.) = 2.54cm <b>1153</b>



## LIMITED WARRANTY

Vestil Manufacturing Corporation ("Vestil") warrants this product to be free of defects in material and workmanship during the warranty period. Our warranty obligation is to provide a replacement for a defective, original part covered by the warranty after we receive a proper request from the Warrantee (you) for warranty service.

### Who may request service?

Only a warrantee may request service. You are a warrantee if you purchased the product from Vestil or from an authorized distributor AND Vestil has been fully paid.

### Definition of "original part"?

An original part is a part used to make the product as shipped to the Warrantee.

### What is a "proper request"?

A request for warranty service is proper if Vestil receives: 1) a photocopy of the Customer Invoice that displays the shipping date; AND 2) a written request for warranty service including your name and phone number. Send requests by one of the following methods:

<u>US Mail</u>	<u>Fax</u>	<u>Email</u>
Vestil Manufacturing Corporation 2999 North Wayne Street, PO Box 507 Angola, IN 46703	(260) 665-1339 <u>Phone</u> (260) 665-7586	<a href="mailto:info@vestil.com">info@vestil.com</a> Enter "Warranty service request" in subject field.

In the written request, list the parts believed to be defective and include the address where replacements should be delivered. After Vestil receives your request for warranty service, an authorized representative will contact you to determine whether your claim is covered by the warranty. Before providing warranty service, Vestil will require you to send the entire product, or just the defective part (or parts), to its facility in Angola, IN.

### What is covered under the warranty?

The warranty covers defects in the following original, dynamic parts: motors, hydraulic pumps, motor controllers, and cylinders. It also covers defects in original parts that wear under normal usage conditions ("wearing parts"), such as bearings, hoses, wheels, seals, brushes, and batteries.

### How long is the warranty period?

The warranty period for original dynamic components is 1 year. For wearing parts, the warranty period is 90 days. Both warranty periods begin on the date Vestil ships the product to the Warrantee. If the product was purchased from an authorized distributor, the periods begin when the distributor ships the product. Vestil may, at its sole discretion, extend a warranty period for products shipped from authorized distributors by up to 30 days to account for shipping time.

### If a defective part is covered by the warranty, what will Vestil do to correct the problem?

Vestil will provide an appropriate replacement for any covered part. An authorized representative of Vestil will contact you to discuss your claim.

### What is not covered by the warranty?

The Warrantee (you) is responsible for paying labor costs and freight costs to return the product to Vestil for warranty service.

### Events that automatically void this Limited Warranty.

- Misuse;
- Negligent assembly, installation, operation or repair;
- Installation/use in corrosive environments;
- Inadequate or improper maintenance;
- Damage sustained during shipping;
- Collisions or other accidents that damage the product;
- Unauthorized modifications: Do not modify the product IN ANY WAY without first receiving written authorization from Vestil.

### Do any other warranties apply to the product?

Vestil Manufacturing Corp. makes no other express warranties. All implied warranties are disclaimed to the extent allowed by law. Any implied warranty not disclaimed is limited in scope to the terms of this Limited Warranty. Vestil makes no warranty or representation that this product complies with any state or local design, performance, or safety code or standard. Noncompliance with any such code or standard is not a defect in material or workmanship.